

JVC



English

中文

عربي

COMPACT COMPONENT SYSTEM

组合音响系统

نظام اجهزة صوتية مركبة

CA-HXZ77D

CA-HXZ55D

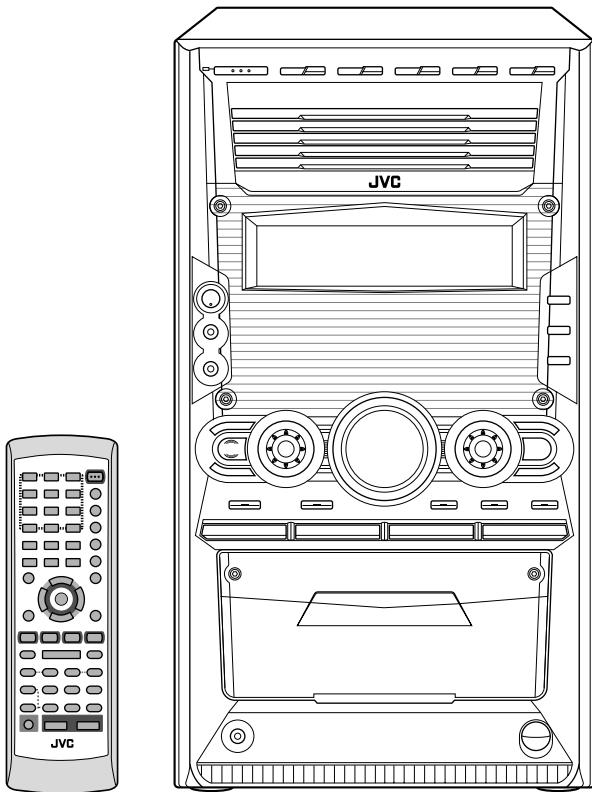

AV COMPU LINK

DIGITAL
dts
SURROUND

COMPACT
disc
SUPER VIDEO

DOLBY
DIGITAL

DVD
VIDEO

MPEG Multichannel

VIDEO
CD

INSTRUCTIONS

使用说明书

كتيب تعليمات التشغيل

Warnings, Cautions and Others

警告，注意及其他须知事项

تحذيرات، تنبيهات واشياء اخرى

Caution— button!

Disconnect the mains plug to shut the power off completely. The  button in any position does not disconnect the mains line. The power can be remote controlled.

注意— 开关！

无论  开关在任何位置，电源线的电源还是没有被切断，若要将电源完全关闭，应把电源插头拔离插座。电源可用遥控器控制。

تحذير — الطاقة!

انزع قابس الطاقة الكهربائية من اجل فصل الطاقة الكهربائية عن الجهاز كليا.
لا يفصل مفتاح الطاقة الكهربائية عندما يكون باي وضع 
الطاقة الكهربائية عن الجهاز. يمكن التحكم عن بعد بالطاقة الكهربائية.

CAUTION

To reduce the risk of electrical shocks, fire, etc.:

1. Do not remove screws, covers or cabinet.
2. Do not expose this appliance to rain or moisture.

CAUTION

- Do not block the ventilation openings or holes. (If the ventilation openings or holes are blocked by a newspaper or cloth, etc., the heat may not be able to get out.)
- Do not place any naked flame sources, such as lighted candles, on the apparatus.
- When discarding batteries, environmental problems must be considered and local rules or laws governing the disposal of these batteries must be followed strictly.
- Do not expose this apparatus to rain, moisture, dripping or splashing and that no objects filled with liquids, such as vases, shall be placed on the apparatus.

注意

为了减少触电，火灾等危险：

1. 请勿擅自卸下螺丝钉，盖子或机壳。
2. 请勿让本机受雨淋或置潮湿环境中。

注意

- 请勿堵塞通风口或通风孔。
(如果通风口或通风孔被报纸或布等堵塞，热量将无法散出。)
- 请勿在本设备上放置任何裸露的火源，如点燃的蜡烛。
- 处理废弃电池时，必须考虑环境问题，并严格遵守当地关于处理废弃电池的有关法律或规定。
- 切勿将本装置暴露于雨水所及、潮湿、滴水或易于溅起水花的地方，亦不要将任何装满液体的物件（如花瓶）放置在本装置上。

تحذير

لتجنب خطر الحريق، الصدمات الكهربائية، الخ:
١. لا تفك البراغي أو الاغطية أو الخزانة.
٢. لا تعرض هذا الجهاز للمطر أو للرطوبة.

تحذير

- لا تغلق فتحات التهوية أو الثقوب.
(في حالة اغلاق فتحات التهوية أو الثقوب بواسطة ورق الصحف أو القماش، الخ، فإنه يمكن ان لا تخرج الحرارة للخارج.)
- لا تضع اية مصادر حرارية مكشوفة، مثل الشموع المضيئة، على الجهاز.
- عند ازالة البطاريات، يجب اخذ مشاكل البيئية بعين الاعتبار ويجب التقيّد بالانظمة المحلية أو القوانين التي تحكم ازالة هذه البطاريات بصورة دقيقة.
- لا تعرض هذا الجهاز للمطر، أو الرطوبة، أو تنقيط الماء، أو رشق الماء ولا تضع اي اوعية مملوءة بالماء أو السوائل مثل مزهريات الورد على هذا الجهاز.

Caution: Proper Ventilation

To avoid risk of electric shock and fire, and to prevent damage, locate the apparatus as follows:

- 1 Front: No obstructions and open spacing.
- 2 Sides/ Top/ Back: No obstructions should be placed in the areas shown by the dimensions below.
- 3 Bottom: Place on the level surface. Maintain an adequate air path for ventilation by placing on a stand with a height of 10 cm or more.

注意：正确通风

为避免发生触电和火警的危险，及防止本机受损，请将本机如下放置：

1. 前面： 没有障碍物及地方开阔。
2. 侧面/顶面/背面： 在图中所示范围中，不应放置任何障碍物。
3. 底部： 放置在水平面上。放置在一个高 10 厘米或以上的台上，以保持足够的通风道。

تحذير: التهوية الصحيحة

لتجنب حصول صدمات كهربائية واطار الحريق ومنع حصول تلف وضرر للجهاز، ركب الجهاز كما يلي:
١ الجهة الامامية: يجب ان لا يكون هنالك عوائق ويجب ان تكون المنطقة مفتوحة امام الجهاز.
٢ الجهات الجانبية / العلوية / الخلفية: يجب عدم وضع عوائق في المناطق المبينة بالابعاد في الاسفل.
٣ القاعدة: يجب وضع الجهاز على سطح منبسط. اترك مسافة كافية من اجل التهوية بواسطة وضع الجهاز على حامل بارتفاع ١٠ سم او اكثر.

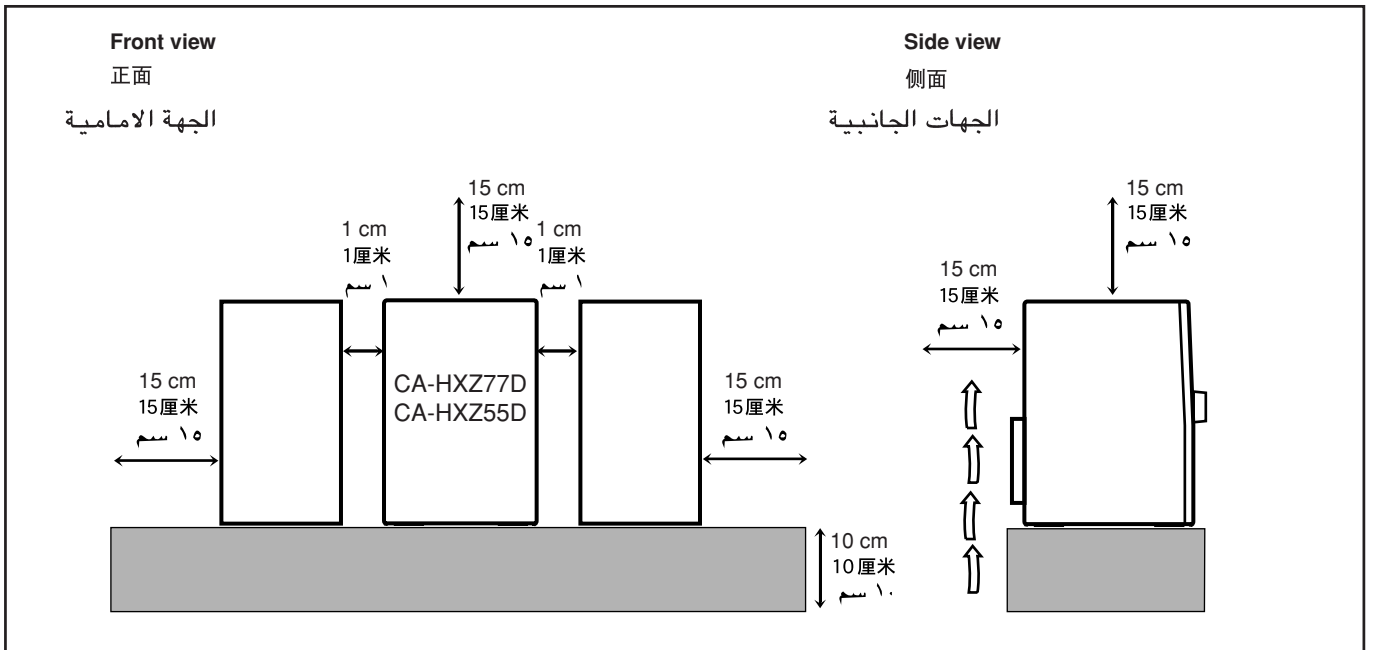

IMPORTANT FOR LASER PRODUCTS

1. CLASS 1 LASER PRODUCT
2. **CAUTION:** Do not open the top cover. There are no user serviceable parts inside the Unit; leave all servicing to qualified service personnel.
3. **CAUTION:** Visible and invisible laser radiation when open and interlock failed or defeated. Avoid direct exposure to beam.
4. REPRODUCTION OF LABEL: CAUTION LABEL, PLACED INSIDE THE UNIT.

关于镭射产品之重要说明

1. 本产品属于1级镭射产品。
2. **注意:** 切勿打开机体的顶盖。里面没有用户可能自行修理的部件。一切维修工作请委托有资格的服务人员进行。
3. **注意:** 当拆开主机，或者内部的联锁装置失灵或损坏时，会有不可见镭射光线射出。请勿要受到镭射光线的直接辐射。
4. 标签的复制标示：注意标签放在主机内部。

مهم للمنتجات الليزرية

١. صنف ١ منتج ليزري
٢. **تحذير:** لا تفتح الغطاء العلوي لا يوجد اجزاء داخل الجهاز يستطيع المستخدم صيانتها؛ اترك جميع اعمال الصيانة مهما كانت للأشخاص المؤهلين والمختصين بالصيانة.
٣. **تحذير:** هنالك أشعة ليزرية مرئية وغير مرئية عند الفتح والعبث بالاجزاء الداخلية او تعطيل اقفال الامان. تجنب التعرض المباشر للأشعة.
٤. ملصق تحذير المنتج: ملصق التحذير CAUTION LABEL، موجود داخل الجهاز.

CAUTION : Visible and invisible laser radiation when open and interlock failed or defeated. AVOID DIRECT EXPOSURE TO BEAM. (e)

WARNING : Synlig och osynlig laserstrålning när den öppnas och spärren är urkopplad. Betrakta ej strålen. (s)

ADVARSEL : Synlig og usynlig laserstrålning når maskinen er åben eller interlocken fejler. Undgå direkte eksponering til stråling. (d)

VARO : Avattaessa ja suojalukitus ohitettuna tai viallisena olet alittiina näkyvälle ja näkymättömälle lasersäteilylle. Vältä säteen kohdistumista suoraan itseesi. (f)

Introduction

We would like to thank you for purchasing one of our JVC products. Before operating this unit, read this manual carefully and thoroughly to obtain the best possible performance from your unit, and retain this manual for future reference.

About This Manual

This manual is organized as follows:

- **The manual mainly explains operations using the buttons on the remote control. You can also use the buttons and controls on the front panel if they have the same or similar names (or marks) as those on the remote control. If operation using the front panel is different from that using the remote control, it is then explained.**
- Basic and common information that is the same for many functions is grouped in one place, and is not repeated for each procedure. For instance, we do not repeat the information about turning on/off the front panel, setting the volume, changing the sound effects, etc., which are explained in the section “Basic Operations” on pages 14 to 17.
- The following symbols are used in this manual:



Gives you warning and caution to prevent damage or risk of fire/electric shock.

Furthermore, it gives you information about what is not good for obtaining the best possible performance from the unit.



Gives you information and hints you should know.

Precautions

Installation

- Install in a place which is level, dry and neither too hot nor too cold—between 5°C and 35°C.
- Install the unit in a location with adequate ventilation to prevent internal heat buildup in the unit.
- Leave sufficient distance between the unit and the TV.
- Keep the speakers (except a center speaker) away from the TV to avoid interference with TV.



DO NOT install the unit in a location near heat sources, or in a place subject to direct sunlight, excessive dust or vibration.

Power sources

- When unplugging the unit from the wall outlet, always pull on the plug, not the AC power cord.



DO NOT handle the AC power cord with wet hands.

Moisture condensation

Moisture may condense on the lens inside the unit in the following cases:

- After starting heating in the room
 - In a damp room
 - If the unit is brought directly from a cold to a warm place
- Should condensation occur, the unit may malfunction. In this case, leave the unit turned on for a few hours until the moisture evaporates, unplug the AC power cord, then plug it in again.

Internal heat

A cooling fan is mounted on the rear panel to prevent heat buildup inside the unit.



DO NOT block the cooling fan and the ventilation openings or holes. If they are blocked by a newspaper or cloth, etc., the heat may not be able to get out.

Others

- Should any metallic object or liquid fall into the unit, unplug the AC power cord and consult your dealer before operating any further.
- If you are not going to operate the unit for an extended period of time, unplug the AC power cord from the wall outlet.



DO NOT disassemble the unit since there are no user serviceable parts inside.

If anything goes wrong, unplug the AC power cord and consult your dealer.

Contents

Location of the Buttons and Controls	3	Advanced Disc Operations	35
Main Unit	3	About the On-screen Bar	36
Remote Control	5	Operation through the On-screen Bar	37
Getting Started	6	Selecting a View Angle	40
Supplied Accessories	6	Selecting the Subtitle Language	40
Putting the Batteries into the Remote Control	6	Selecting the Audio Language	41
Connecting Antennas	6	Selecting the Audio Channel	41
Connecting Speakers	7	Special Picture Playback	42
Connecting a TV	8	Changing the VFP Setting	43
Connecting Other Equipment	9	MP3/JPEG Disc Playback	44
Adjusting the Voltage Selector	10	Operations through the MP3/JPEG CONTROL	
Setting the DVD Player	10	Screens	45
Setting the Clock	13	Recording	46
Basic Operations	14	Recording on a Tape	47
Turning On the Power	15	Synchronized Recording	48
Selecting the Source	15	Enjoying Karaoke	49
Adjusting the Volume	15	Singing Along (Karaoke)	50
Changing the Display Brightness	16	Microphone Mixing	51
Turning Off the Key-touch Tone	16	Reserving Karaoke Songs	
Adjusting the Front Speaker Output Balance	16	—Karaoke Program Play	52
Reinforcing the Bass Sound	16	Using the Timers	53
Selecting the Sound Modes	16	Using Daily Timer	54
Creating Your Own Sound Mode—User Mode	17	Using Recording Timer	56
Changing the Scanning Mode	17	Using Sleep Timer	57
Prohibiting Disc Ejection—Tray Lock	17	Timer Priority	57
Using Surround Mode	18	Choice Menu Operations	58
Available Surround Modes	19	Introducing the Choice Menus	59
Activating Surround Mode	19	Operating Procedure	60
Adjusting DSP Modes and Output Sound	20	■ Language selection menu—LANGUAGE	61
Listening to FM and AM Broadcasts	21	■ Picture setting menu—PICTURE	61
Setting the AM Tuner Interval Spacing	22	■ Audio selection menu—AUDIO	62
Tuning in to a Station	22	■ Speaker setting menu—SPK. SETTING	63
Presetting Stations	22	■ Other setting menu—OTHERS	63
Tuning in to a Preset Station	22	Restricting the Access Level—Parental Lock	64
Playing Back Tapes	23	■ Setting Parental Lock	64
Playing Back a Tape	24	■ Changing the Parental Lock setting	65
Locating the Beginning of a Song—Music Scan	24	■ Releasing Parental Lock temporarily	65
Playing Back Discs	25	Additional Information	67
Disc Information	26	Using AV COMPU LINK Control System	67
Loading Discs	28	Output Signals through the OPTICAL DIGITAL	
Continuous Playback	29	OUTPUT Terminal	68
Changing the Disc to Play Back	30	Language Code List	68
Basic Disc Operations	30	Glossary	69
Playing Back by Using the Disc Menu	32	Maintenance	70
Repeating Playback—Repeat Play	32	Troubleshooting	71
Programming the Playing Order—Program Play	33	Specifications	72
Playing at Random—Random Play	34		

Location of the Buttons and Controls

Become familiar with the buttons and controls on your unit.

Main Unit

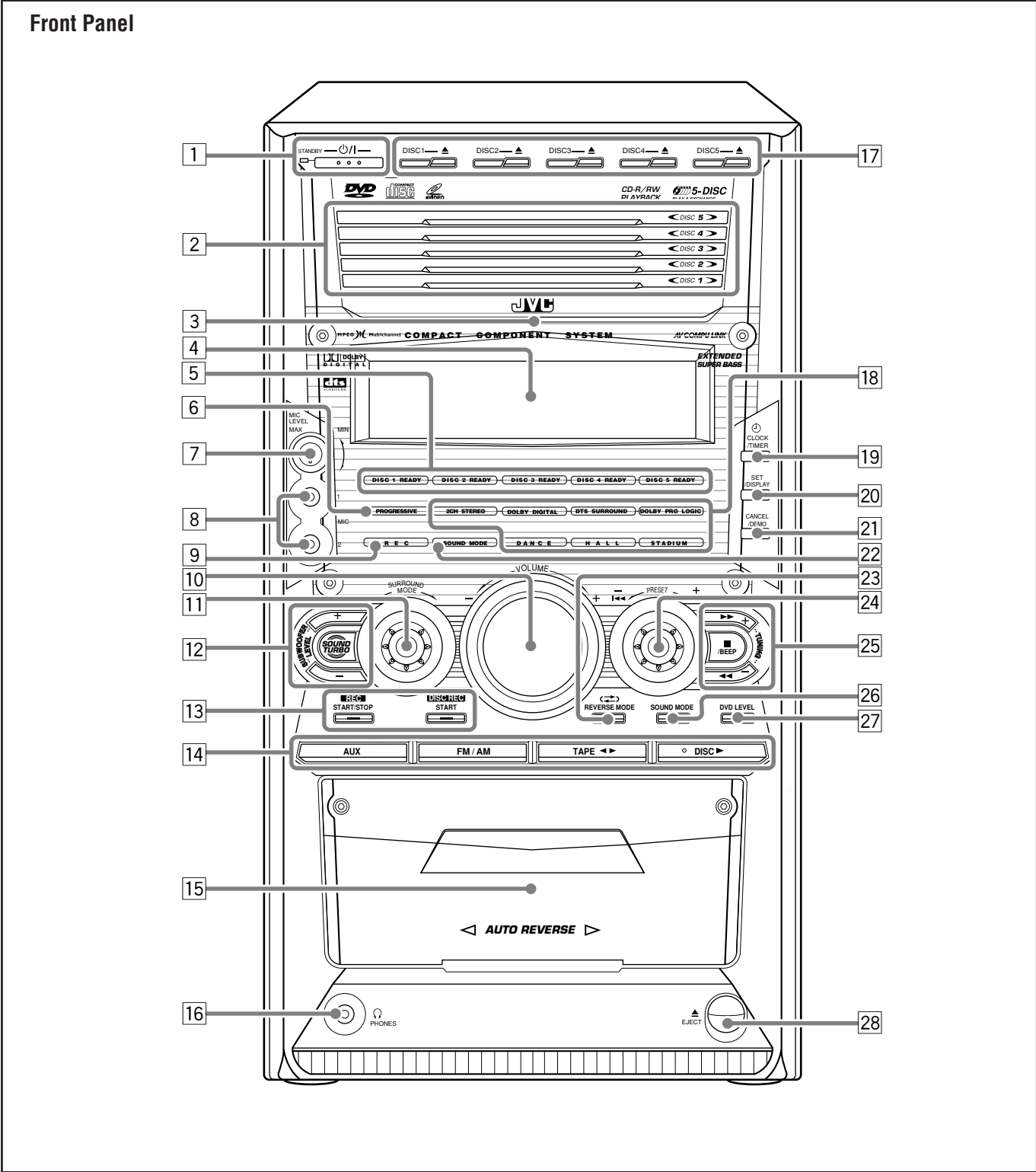

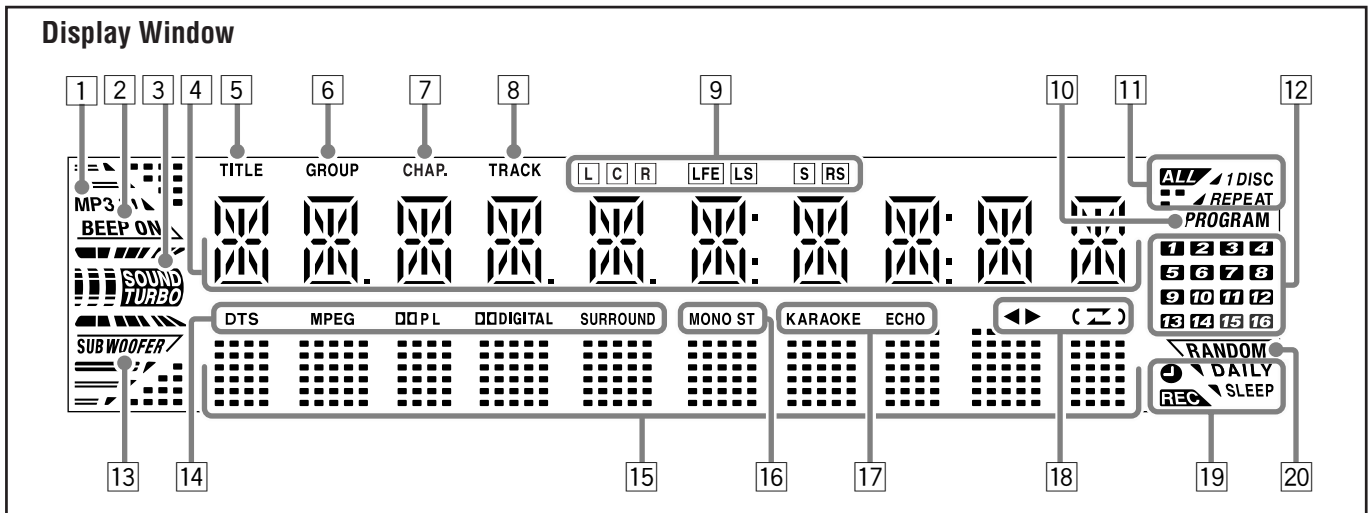

See pages in parentheses for details.

Front Panel

- 1 Φ /I (standby/on) button and STANDBY lamp (15, 22, 55, 56)
- 2 Disc trays
 - DISC1 – DISC5
- 3 Remote sensor
- 4 Display window
- 5 DISC ready lamps (28)
 - DISC 1 READY – DISC 5 READY
- 6 PROGRESSIVE lamp (17)
- 7 MIC LEVEL control (50, 51)
- 8 MIC 1/2 jacks (50)
- 9 REC lamp (47, 48)
- 10 VOLUME + / – control (15, 50, 51)
- 11 SURROUND MODE control (19, 20)
- 12 SUBWOOFER LEVEL + / – buttons (16)
 - SOUND TURBO button (16)
- 13 Recording buttons
 - REC START/STOP button (47, 48, 51, 56)
 - DISC REC START button (48)
- 14 Source buttons (15)

Pressing one of these buttons also turns on the unit.

 - AUX, FM/AM (22), TAPE \blacktriangleleft \blacktriangleright (24, 47), DISC \blacktriangleright (29, 32, 44, 45, 48, 51, 52)
- 15 Cassette holder (24, 47, 48)
- 16 Φ PHONES jack (15)
- 17 Disc number buttons (29, 30, 44, 48) and \blacktriangle (disc tray open/close) buttons (17, 28, 30, 65)
 - DISC1 – DISC5
- 18 Surround mode lamps
 - 2CH STEREO, DOLBY DIGITAL, DTS SURROUND, DOLBY PRO LOGIC, DANCE, HALL, STADIUM
- 19 Φ CLOCK/TIMER button (13, 54 – 57)
- 20 SET/DISPLAY button (13, 17, 22, 54 – 57)
- 21 CANCEL/DEMO button (10, 13, 54 – 57)
- 22 SOUND MODE lamp (16)
- 23 \blacktriangleleft \blacktriangleright REVERSE MODE button (24, 47, 48)
- 24
 - PRESET + / – control (22)
 - \blacktriangleright \blacktriangleleft / \blacktriangleleft \blacktriangleright (forward skip/reverse skip) control (13, 17, 30, 34, 54 – 56)

- 25
 - TUNING + / – buttons (22)
 - \blacktriangleright \blacktriangleleft / \blacktriangleleft \blacktriangleright (forward search/reverse search) buttons (17, 24, 31)
 - \blacksquare (stop) button
 - BEEP button (10, 16)
- 26 SOUND MODE button (16)
- 27 DVD LEVEL button (31)
- 28 \blacktriangle EJECT button for cassette deck (24, 47, 48)

Display Window

- 1 MP3 indicator (28)
- 2 BEEP ON indicator (10, 16)
- 3 SOUND TURBO indicator (16)
- 4 Main display
 - Shows the source name, frequency, etc.
- 5 TITLE indicator (28)
- 6 GROUP indicator (28)
- 7 CHAP. indicator (28)
- 8 TRACK indicator (28)
- 9 Incoming signal indicators (20)
 - L, C, R, LFE, LS, S, RS
- 10 PROGRAM indicator (33, 34, 52)
- 11 Repeat indicators (33, 39, 45)
 - REPEAT, 1 DISC, ALL
- 12 Chapter/track number indicators
- 13 SUBWOOFER indicator (16)
- 14 Surround mode indicators (19, 59)
 - DTS, MPEG, $\square\square$ PL, $\square\square$ DIGITAL
 - SURROUND
- 15 Audio level indicators

When one of the 6 preset sound modes is activated, this will function as illumination display. For details, see “Selecting the Sound Modes” on page 16.
- 16 Tuner operation indicators (22)
 - MONO, ST (stereo)
- 17 Karaoke operation indicators (50, 52)
 - KARAOKE, ECHO
- 18 Tape operation indicators (24, 47, 48)
 - \blacktriangleleft \blacktriangleright (tape direction), \blacktriangleleft \blacktriangleright (Reverse mode)
- 19 Timer indicators (54 – 57)
 - DAILY (Daily Timer), SLEEP (Sleep Timer), REC (Recording Timer), Φ (Timer)
- 20 RANDOM indicator (34)

Location of the Buttons and Controls (continued)

Remote Control

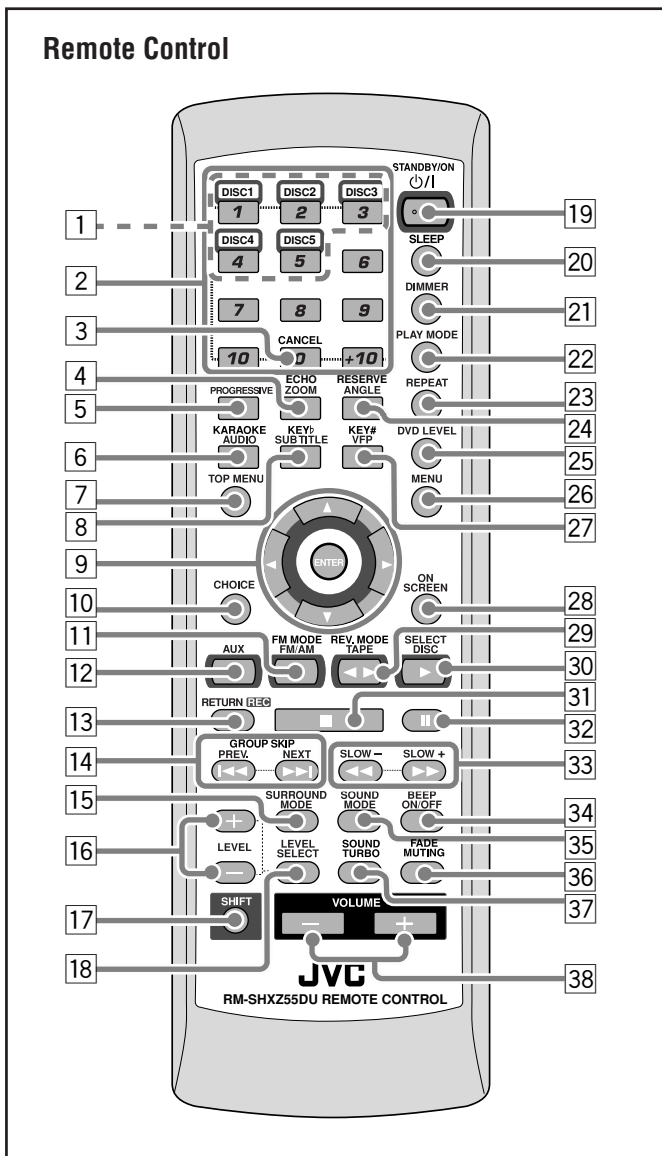

See pages in parentheses for details.

- 1 Disc number buttons* (29, 30, 33, 44, 48)
 - DISC1 – DISC5
- 2 Number buttons (22, 30 – 33, 38, 44, 52, 64, 65)
- 3 CANCEL button* (34, 52)
- 4
 - ZOOM button (42)
 - ECHO button* (50, 51)
- 5 PROGRESSIVE button (17)
- 6
 - AUDIO button (41, 51, 52)
 - KARAOKE button* (50 – 52)
- 7 TOP MENU button (32)
- 8
 - SUBTITLE button (40)
 - KEY \flat button* (50)
- 9
 - Cursor (\blacktriangleleft / \blacktriangleright / \blacktriangleup / \blacktriangledown) buttons
 - ENTER button
- 10 CHOICE button (10 – 12, 59 – 65)
- 11
 - FM/AM button (15, 22)
 - Pressing this button also turns on the unit.
 - FM MODE button* (22)
- 12 AUX button (15)
- 13
 - Pressing this button also turns on the unit.
 - RETURN button (32)
 - REC button* (47)
- 14
 - $\blacktriangleright\blacktriangleright$ and $\blacktriangleleft\blacktriangleleft$ buttons (22, 24, 30, 34, 44)
 - PREV. and NEXT buttons (32)
 - GROUP SKIP $\blacktriangleright\blacktriangleright$ / $\blacktriangleleft\blacktriangleleft$ buttons* (44, 48)
- 15 SURROUND MODE button (19, 20)
- 16 LEVEL + / – buttons (16, 20)
- 17 SHIFT button
- 18 LEVEL SELECT button (16, 20)
- 19 STANDBY/ON ϕ /I button (15)
- 20 SLEEP button (57)
- 21 DIMMER button (16)
- 22 PLAY MODE button (34, 52)
- 23 REPEAT button (32, 33, 45)
- 24
 - ANGLE button (40)
 - RESERVE button* (52)
- 25 DVD LEVEL button (31)
- 26 MENU button (32)
- 27
 - VFP button (43)
 - KEY # button* (50)
- 28 ON SCREEN button (31, 36 – 40)
- 29
 - TAPE $\blacktriangleleft\blacktriangleright$ button (15, 24)
 - Pressing this button also turns on the unit.
 - REV. MODE button* (24, 47, 48)
- 30
 - DISC \blacktriangleright (play) button
 - Pressing this button also turns on the unit.
 - SELECT button (32)
- 31 \blacksquare (stop) button
- 32 II (pause) button (42, 44, 48)
- 33
 - SLOW + / SLOW – buttons (42)
 - $\blacktriangleright\blacktriangleright$ and $\blacktriangleleft\blacktriangleleft$ buttons (24, 31, 48)
- 34 BEEP ON/OFF button (10, 16)
- 35 SOUND MODE button (16)
- 36 FADE MUTING button (15)
- 37 SOUND TURBO button (16)
- 38 VOLUME + / – buttons (15, 50)

* These buttons function when pressed with SHIFT (17).

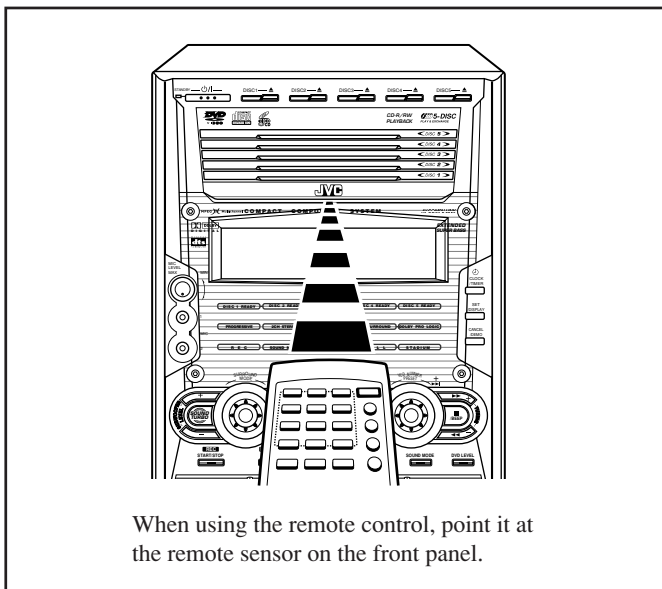

When using the remote control, point it at the remote sensor on the front panel.

Supplied Accessories

Make sure that you have all the following items. The number in parentheses indicates the quantity of each piece supplied.

- AM loop antenna (1)
- FM antenna (1)
- Remote control (1)
- Batteries (2)
- Composite video cord (1)
- AC plug adaptor (1)

If anything is missing, consult your dealer immediately.

Putting the Batteries into the Remote Control

Insert the batteries—R6(SUM-3)/AA(15F)—into the remote control, by matching the polarity (+ and –) on the batteries with the + and – markings on the battery compartment. When the remote control can no longer operate the unit, replace both batteries at the same time.

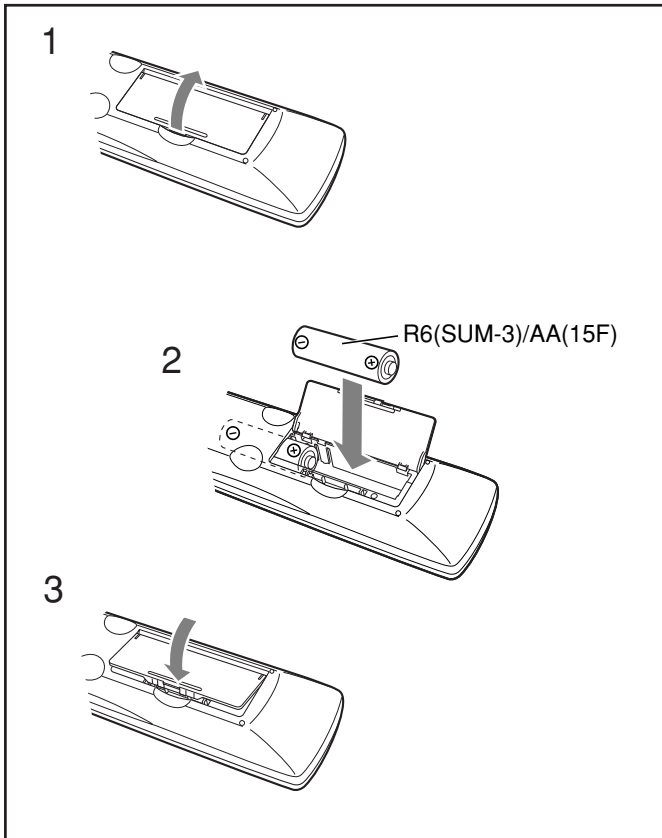

- DO NOT use an old battery together with a new one.
- DO NOT use different types of batteries together.
- DO NOT expose batteries to heat or flame.
- DO NOT leave the batteries in the battery compartment when you are not going to use the remote control for an extended period of time. Otherwise, the remote control will be damaged from battery leakage.

Connecting Antennas

FM antenna

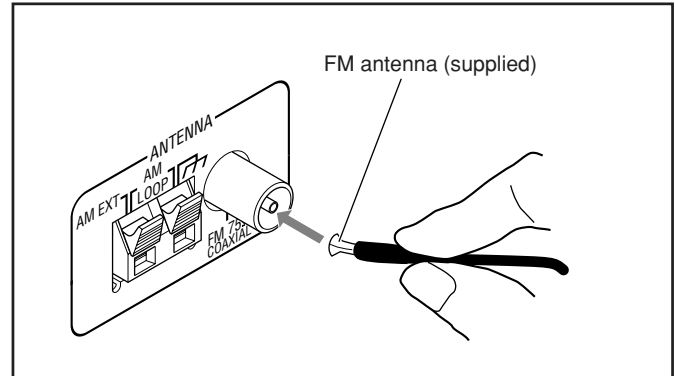

- 1 Attach the FM antenna to the FM 75 Ω COAXIAL terminal.
- 2 Extend the FM antenna.
- 3 Fasten it up in the position which gives you the best reception, then fix it on the wall, etc.



About the supplied FM antenna

The FM antenna supplied with this unit can be used as temporary measure. If reception is poor, you can connect an outdoor FM antenna.

To connect an outdoor FM antenna

Before connecting the antenna, disconnect the supplied FM antenna.

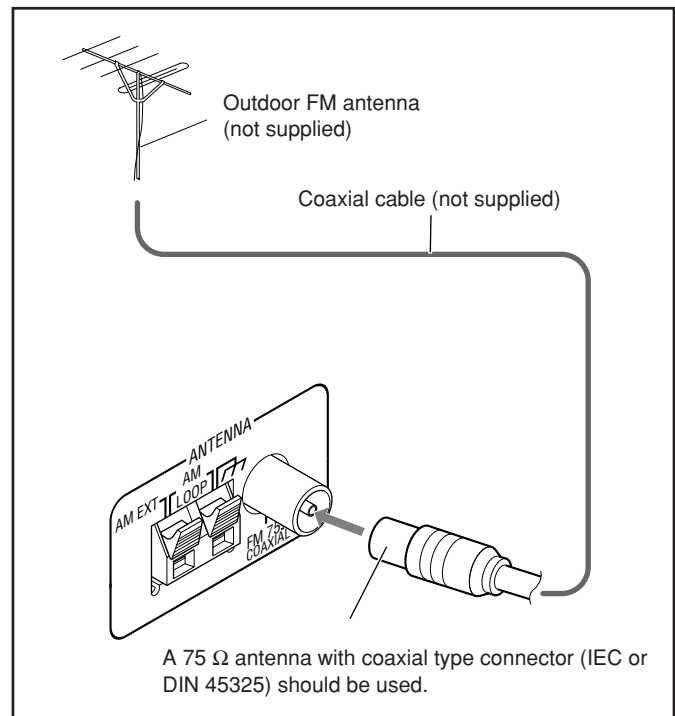

Getting Started (continued)

AM antenna

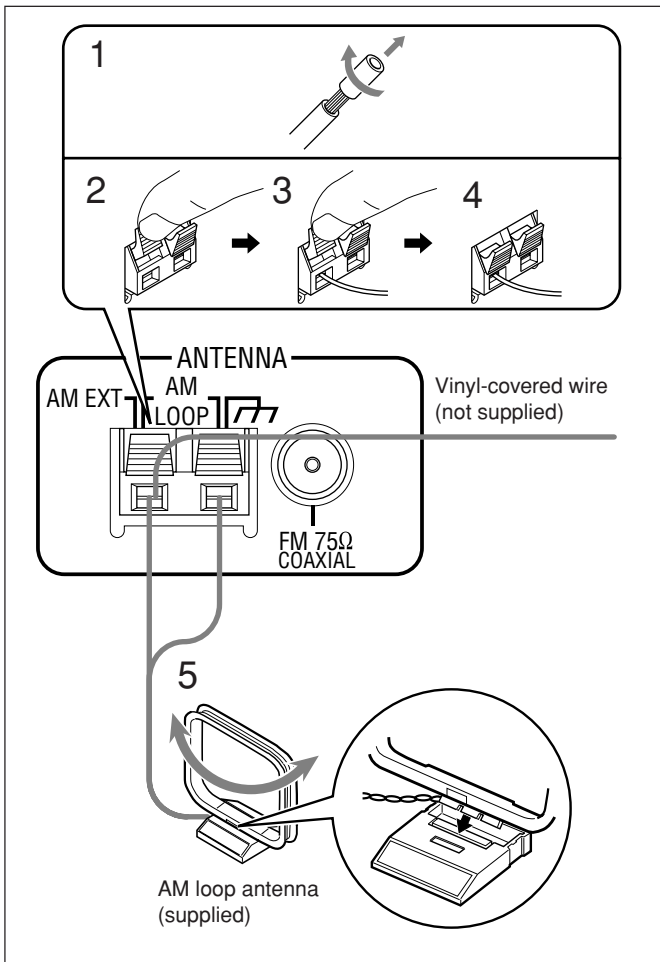

- 1 If the cords are covered with insulation, remove a short section of insulation at the end of each cord by twisting and pulling it off.
- 2 Press and hold the clamp of the AM LOOP terminals on the rear of the unit.
- 3 Insert the AM loop antenna to the AM LOOP terminals as illustrated.
- 4 Release your finger from the clamp.
- 5 Turn the AM loop antenna until you have the best reception.

To connect an outdoor AM antenna

When reception is poor, connect a single vinyl-covered wire to the AM EXT terminal and extend it horizontally. The AM loop antenna must remain connected.



For better reception of both FM and AM

- Make sure the antenna conductors do not touch any other terminals and connecting cords.
- Keep the antennas away from metallic parts of the unit, connecting cords, and the AC power cord.

Connecting Speakers

IMPORTANT: Use only speakers with the same speaker impedance as indicated by the speaker terminals on the rear of the unit.

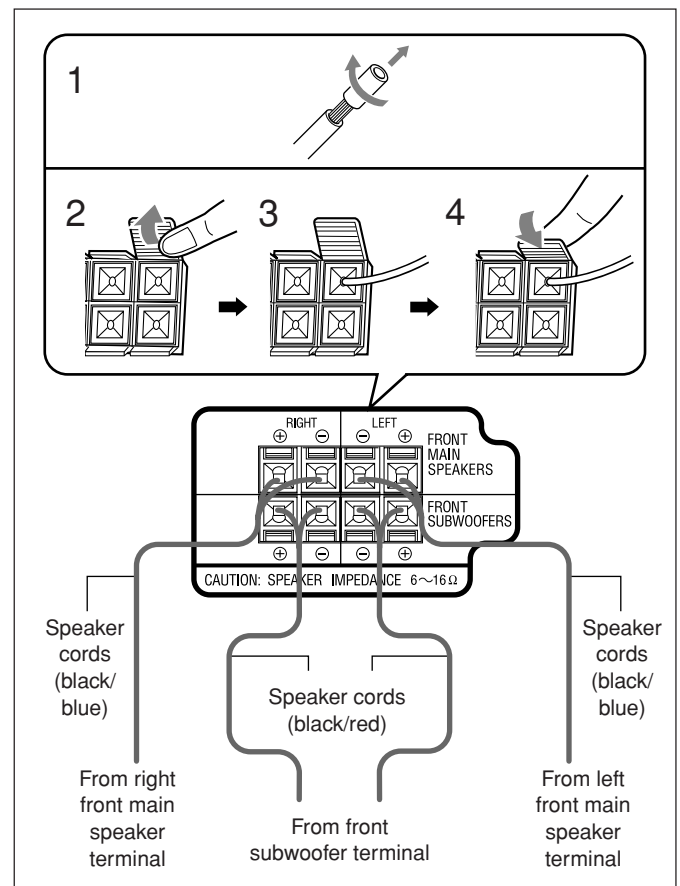

- 1 If the cords are covered with insulation, remove a short section of insulation at the end of each cord by twisting and pulling it off.
- 2 Open the clamp of the speaker terminals on the rear of the unit.
- 3 Insert the end of the speaker cord into the terminal as illustrated.

Match the same polarity: (+) to (+) and (-) to (-).

Speaker	Terminal color	
	(+)	(-)
FRONT MAIN SPEAKERS	Blue	Black
FRONT SUBWOOFERS	Red	Black

- 4 Close the speaker terminals.



DO NOT connect more than one speaker to each speaker terminal.

To connect a center speaker and surround speakers

By connecting a center speaker to the CENTER SPEAKER jack and surround speakers to the SURROUND SPEAKERS jacks, you can enjoy multi-channel Surround modes. (See pages 18 to 20.)

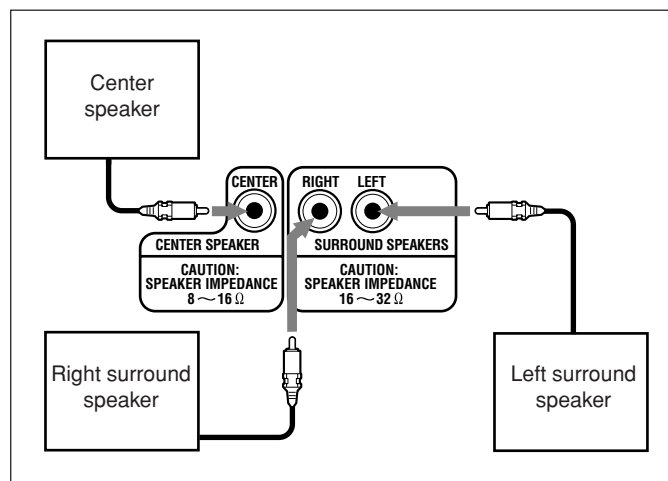

Ideal speaker layout

To enjoy multi-channel sound, locate speakers as follows. If you cannot locate them like this, adjust the speaker setting by using the choice menu. (See page 63.)

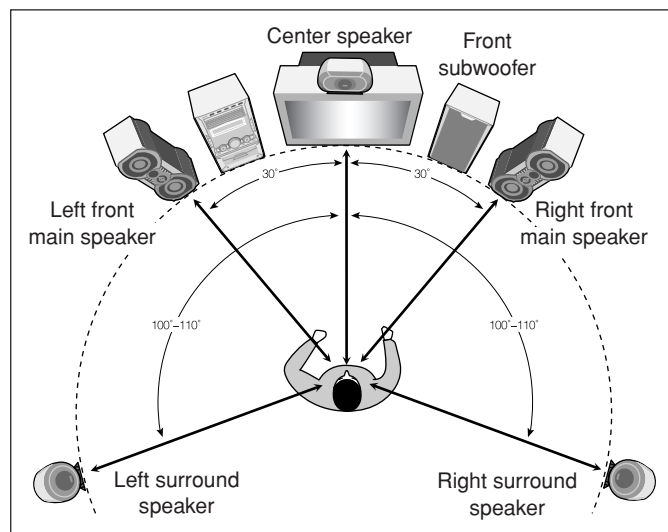

Placing the front subwoofer

You can place the front subwoofer wherever you like since bass sound is non-directional. However, it is recommended to place it in front of you.



DO NOT place a center speaker and surround speakers on the front main speakers or the front subwoofer.

Connecting a TV

Connect your TV and this unit using the composite video cord (supplied), an S-video cord (not supplied) or Component video cord (not supplied).

- You can also connect a JVC's TV through the AV COMPU LINK control system. (See page 67.)

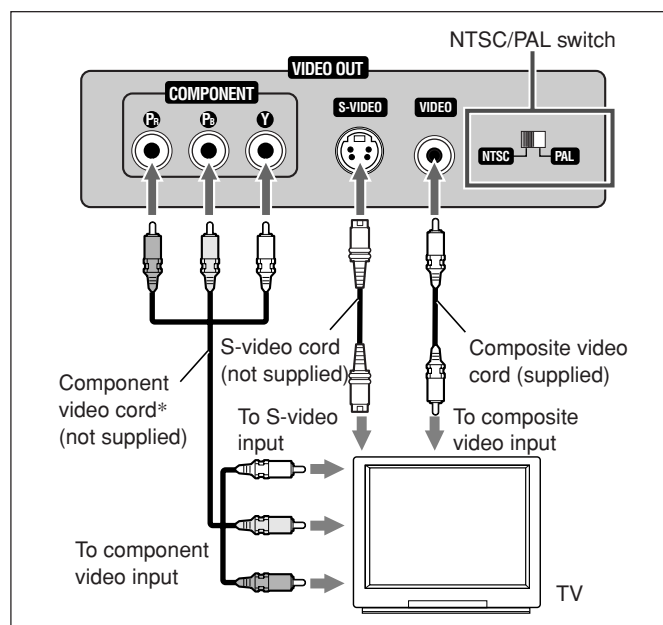

On video connection

- By using S-video or component video cord, you can get a better picture quality—in the order: composite < S-video < component.
- To enjoy the progressive video picture, connect the TV compatible with the progressive video input using component video cord, then change the scanning mode correctly (see “Changing the Scanning Mode” on page 17). You can enjoy the progressive scanning mode only when the color system of your TV is NTSC (see “To select the color system” on page 9).

Getting Started (continued)

To select the color system

You need to select the color system setting of this unit to match to your TV.

Set the NTSC/PAL switch on the rear **while in standby mode** correctly by referring to the table below.

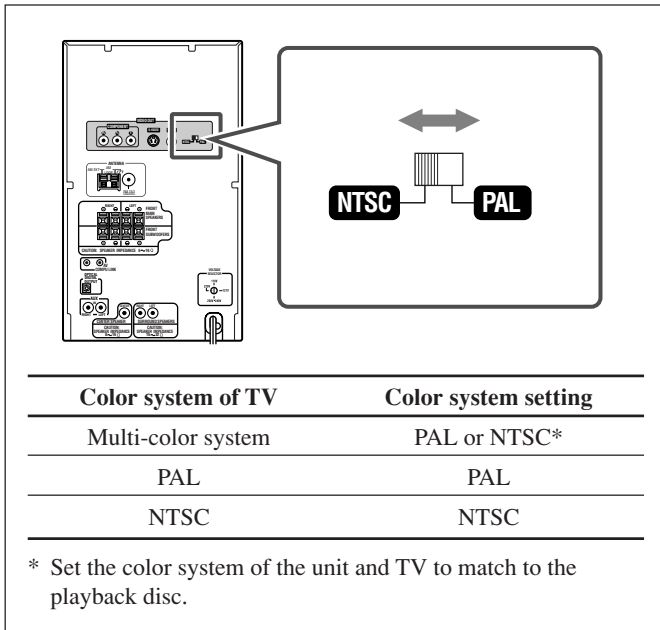

- Before playing back a disc, it is also required to select the correct "MONITOR TYPE" in the PICTURE menu according to the aspect ratio of your TV. (See page 61.)



If you play back an NTSC disc with this setting set to "PAL"

You can watch the playback pictures (the disc will be reproduced using "PAL 60" format), but the TV screen may roll over upward and downward rapidly.



If you play back a PAL disc with this setting set to "NTSC"

You can watch the playback pictures, but the following symptoms may occur:

- The items on the disc menu will be blurred, and be shown slightly shifted when highlighted.
- The aspect ratio of the picture may differ from the original aspect ratio.
- The picture movement is not smooth.

Connecting Other Equipment

You can connect other equipment such as a digital decoder to reproduce multi-channel sounds or audio equipment which can be used as a playback device.

When you connect and use such equipment, refer also to its manual.



- DO NOT connect other equipment while the power is on.
- DO NOT plug in any equipment until all connections are complete.

To connect audio equipment with an optical digital input terminal—such as portable MD recorder

By using an optical digital cord (not supplied), you can connect audio equipment with an optical digital input terminal.

- Before playing back a disc, select "DIGITAL AUDIO OUTPUT" in the "AUDIO" menu according to audio equipment connected to the OPTICAL DIGITAL OUTPUT terminal. (See pages 62 and 68.)

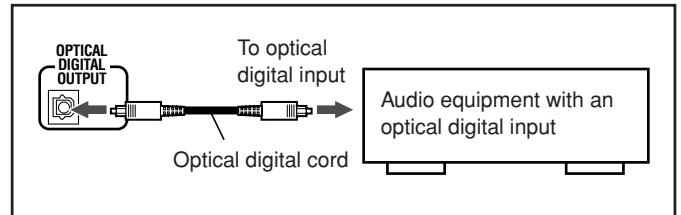

To connect analog audio equipment

By using an RCA pin plug cord (not supplied), you can connect equipment with analog audio output jacks such as an MD player, a TV, etc.

- Be sure that the plugs of the audio cords and the jacks on the rear of the unit are color-coded:
White plugs and jacks are for left audio signals, and red ones for right audio signals.

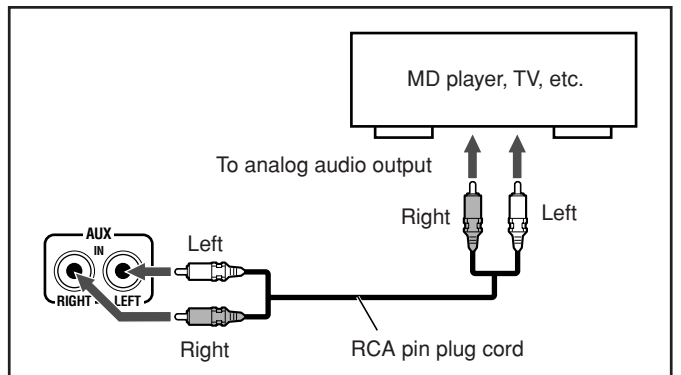

To listen to or to record the sound from analog audio equipment connected to the AUX IN jacks, select "AUX" as the source to play. (See page 15.)

Adjusting the Voltage Selector

Before plugging in the unit, set the correct voltage for your area with the voltage selector on the rear of the unit.

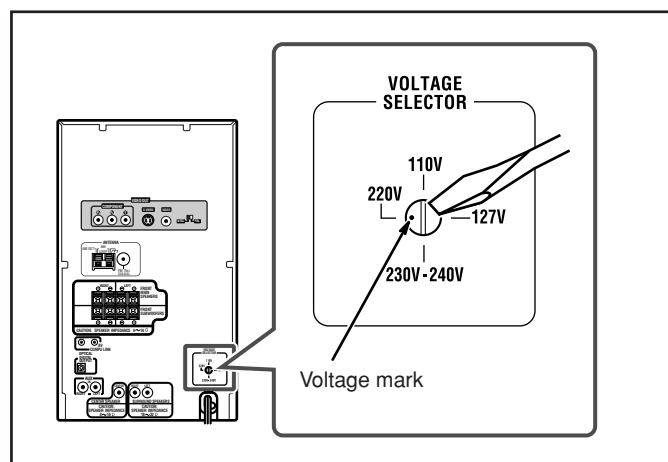

Use a screwdriver to rotate the voltage selector so that the voltage mark is pointing at the same voltage as where you are plugging in the unit. (See also the back cover page.)



DO NOT plug in before setting the voltage selector on the rear of the unit and all connection procedures are complete.

Now, you are ready to plug in the unit and any other connected equipment.

- If the wall outlet does not match the AC plug, use the supplied AC plug adaptor.

IMPORTANT: Be sure to check that all connections are done before plugging the AC power cord into a wall outlet.

When connecting the AC power cord to a wall outlet, the unit automatically starts display demonstration.

To cancel the display demonstration, press and hold CANCEL/DEMO on the front panel until "DEMO OFF" appears on the display.



DEMO OFF

- When you press other buttons on the front panel or on the remote control, the demonstration stops temporarily. It will start automatically again (if no operation is done for about 2 minutes) unless you cancel it by pressing CANCEL/DEMO.

To cancel only beep sounds during the demonstration, press BEEP ON/OFF or press and hold BEEP (■) for more than 2 seconds on the front panel. The BEEP ON indicator goes off from the display.



On the remote control



On the front panel

- "0:00" flashes on the display until you set the built-in clock. After setting the clock, the clock time will appear on the display while the unit is turned off.

To set the built-in clock, see "Setting the Clock" on page 13.

To start the display demonstration manually, press and hold CANCEL/DEMO again.

"DEMO START" appears on the display.

- Each time you press and hold the button, the display demonstration turns on and off alternately.

Setting the DVD Player

You need to set the following before starting playback, using the choice menu shown on the TV.

- You can select the language used in the choice menu.
- For further information about the choice menu, see pages 58 to 66.

Make sure you have selected the correct input mode on the TV before setting.

Step 1: Select the on-screen language for the choice menu.

Step 2: Select the monitor type according to your TV.

Is audio equipment connected to the OPTICAL DIGITAL OUTPUT terminal?

YES

NO

Step 3: Select the output signal type.

Setting is finished.

Go to the next page to start the initial setup.



If no operation is done for about 5 minutes while the choice menu is shown on the TV

The Screen Saver automatically works to prevent the TV screen from being damaged.

To cancel the Screen Saver, cancel this function. (See page 61.)

Getting Started (continued)

For the following procedure, use the remote control.

To select the on-screen language for the choice menu—**Step 1:**

1 Turn on the TV and select the correct input mode on the TV.

2 Press DISC , then .

The unit turns on and the opening screen appears on the TV.

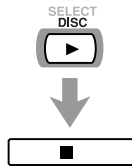

3 Press CHOICE.

The LANGUAGE menu appears on the TV.

- When shipped from the factory, the on-screen language used for the choice menu is set to “ENGLISH.”

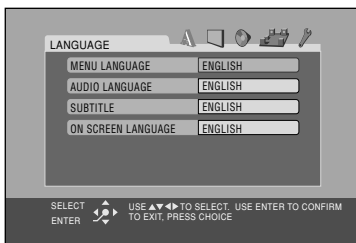

4 Press cursor  repeatedly to select (highlight) “ON SCREEN LANGUAGE.”



5 Press ENTER.

The pop-up window listing the selectable language opens.

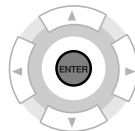

6 Press cursor  /  repeatedly to select (highlight) the desired language.

You can choose the language from among ENGLISH, Chinese (中国语), and Spanish (ESPAÑOL).

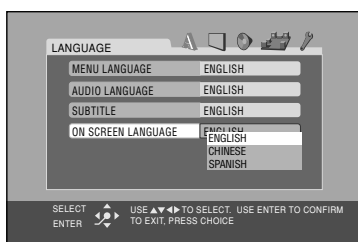
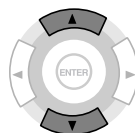

Ex.: “ENGLISH” is selected.

7 Press ENTER.

The language for the choice menu changes to the one you chose.

- Other indications shown on the TV while you operate the unit will also be shown in the language you chose.

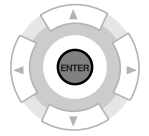

Go to “To select the monitor type—Step 2” below.

To select the monitor type—**Step 2:**

You need to select the monitor type for playing DVDs recorded with the aspect ratio of 16:9.

1 Press cursor  /  repeatedly to display “PICTURE.”

The PICTURE menu appears on the TV.

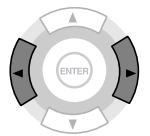
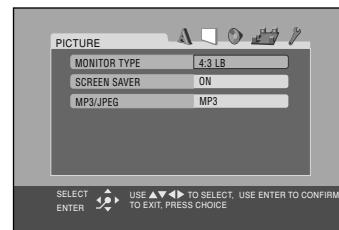

2 Press cursor  to select (highlight) “MONITOR TYPE.”



3 Press ENTER.

The pop-up window listing the selectable monitor type opens.

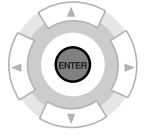

4 Press cursor  /  repeatedly to select (highlight) the monitor type.

For a normal (conventional) TV, select [4:3 LB] or [4:3 PS].

For a wide-screen TV, select [16:9 NORMAL] or [16:9 AUTO].

- For details of the monitor type, see page 61.

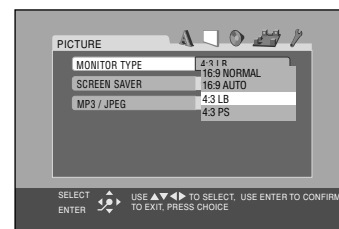
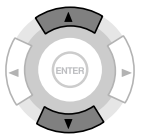

Ex.: “4:3 LB” is selected.

5 Press ENTER.

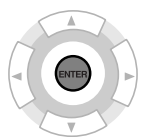

Go to “To adjust the speaker distance—Step 3” on the next page.

To adjust the speaker distance—Step 3:

You need to adjust the each speaker's distance from where you usually take seat (listening position) to get the best surround effect.

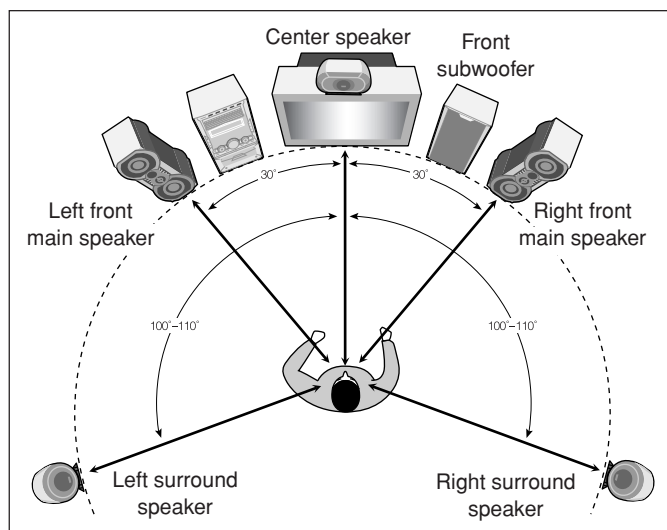

1 Press cursor **▶** / **◀** repeatedly to display “SPK. SETTING.”

The SPK. SETTING menu appears on the TV.

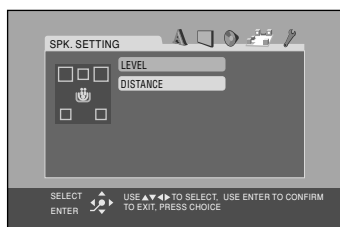

2 Press cursor **▼** to select (highlight) “DISTANCE.”

3 Press ENTER.

The DISTANCE submenu appears on the TV.

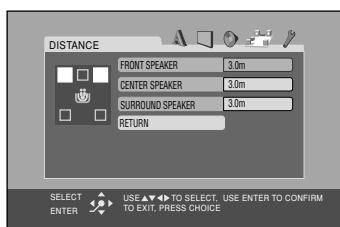

4 Press cursor **▼** / **▲** repeatedly to select (highlight) the speaker to adjust the distance.

5 Press ENTER.

The pop-up window listing the selectable speaker distance opens.

6 Press cursor **▼** / **▲** repeatedly to select (highlight) the desired speaker distance.

For each speaker (FRONT SPEAKER, CENTER SPEAKER, SURROUND SPEAKER), set the distance from the listening point within the range of 0.3 m to 9.0 m in 0.3 m intervals.

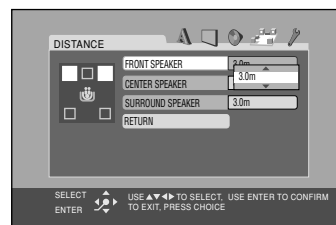

Ex.: “3.0m” is selected.

7 Press ENTER.

8 Repeat steps 4 to 7 to adjust other speakers' distance if necessary.

The initial setting is finished.

To return to the SPK. SETTING menu, select (highlight) “RETURN” on the distance submenu, then press ENTER.

To exit from the choice menu, press CHOICE.

The choice menu goes off.

- For more details about the choice menu, see pages 58 to 66.

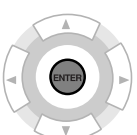
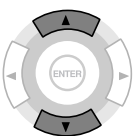
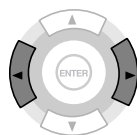
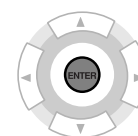
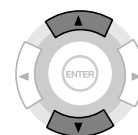

Getting Started (continued)

Setting the Clock

You can set the clock when the unit is either turned on or off (on standby).

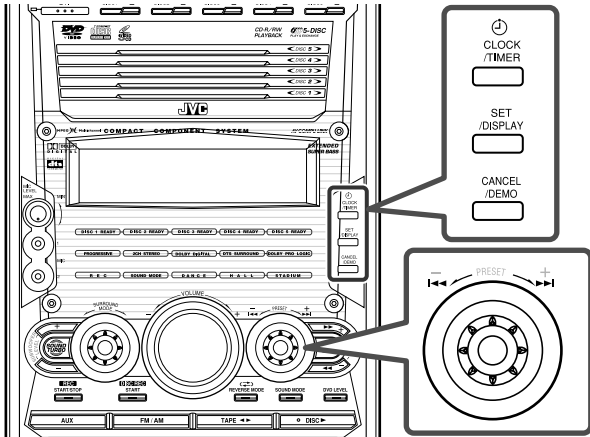

On the front panel ONLY:

1 Press CLOCK/TIMER.

“0:00” appears on the display with the hour digit flashing.



2 Turn / to adjust the hour.

- As you turn the control, the hour digit changes continuously.



3 Press SET/DISPLAY to set the hour.

The minute digit starts flashing.



- If you want to change the hour again, press CANCEL/DEMO. The hour digit starts flashing again.

4 Turn / to adjust the minute.

- As you turn the control, the minute digit changes continuously.



5 Press SET/DISPLAY to finish setting the clock.

“CLOCK OK” appears on the display, then the built-in clock starts.

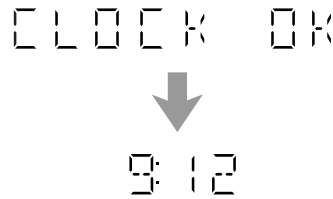

To check the clock time while playing a source

Press and hold SET/DISPLAY.

- Each time you press and hold the button, the source indication and the clock time alternate on the display.

To adjust the clock again

If you have set the clock before, press CLOCK/TIMER repeatedly until the clock setting mode is selected.

- Each time you press the button, the clock/timer setting modes change as follows:

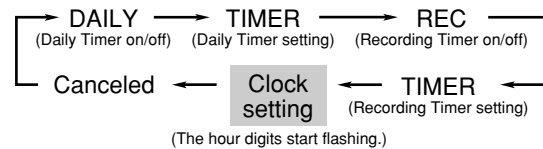

When you unplug the AC power cord or if a power failure occurs

The clock loses its setting and resets to “0:00.” If this happens, set the clock again.



The clock may gain or loss 1 to 2 minutes per month

If this happens, set the clock again.

Basic Operations

The buttons emphasized in the illustration below are used and explained in the following section (pages 15 to 17).

Remote Control

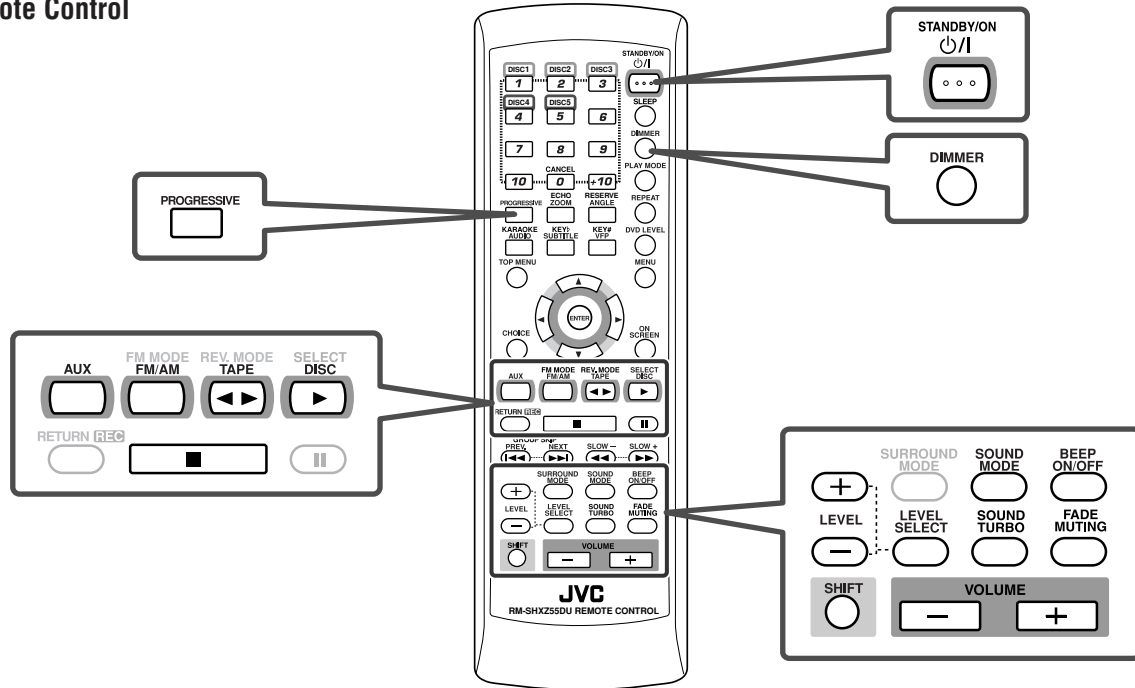

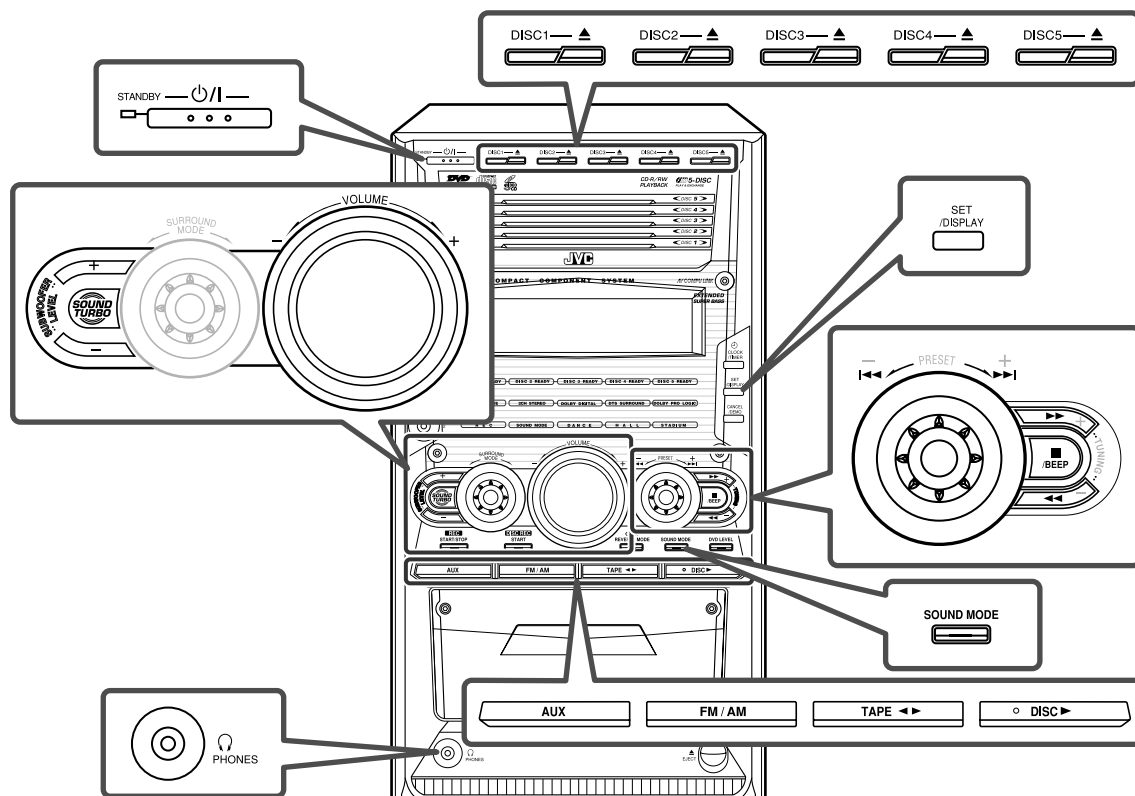

Front Panel





Basic Operations (continued)

Turning On the Power

Press **STANDBY/ON**  (or  on the front panel).

The STANDBY lamp goes off.
“POWER ON” appears on the display.

P O W E R O N

To turn off the unit (standby), press **STANDBY/ON**  (or  on the front panel) again.

The STANDBY lamp lights up.

- When you use the Resume function (see page 63), turning off the power while playing a disc stops playback and stores the interrupted point.

By pressing **DISC** , you can turn on the unit and start playback again from the position where you have stopped—Resume Play. (“RESUME” appears on the display.)

- A little power is always consumed even while the unit is on standby.

To turn off the power supply completely, unplug the AC power cord from the AC outlet.



When you unplug the AC power cord or if a power failure occurs

The clock is reset to “0:00” immediately, while the tuner preset stations (see page 22) will be erased in a few days.

Selecting the Source

To select the tuner as the source, press **FM/AM**.

The unit automatically turns on (when the unit is on standby), and the last selected band appears on the display.

- Each time you press the button, the band alternates between FM and AM.

• For more detailed operations, see pages 21 and 22.

To select the disc player as the source, press **DISC** .

The unit automatically turns on (when the unit is on standby), and “READING” appears on the display for a while.

- Playback will start if a disc is in the disc tray.
- “NO DISC” will appear on the display if a disc is not loaded.

To stop playback, press .

• For more detailed operations, see pages 25 to 45.

To select the tape as the source, press **TAPE**  .

The unit automatically turns on (when the unit is on standby), and “TAPE” appears on the display.

- Play will start if a tape is in the cassette holder.

To stop playback, press .

• For more detailed operations, see pages 23 and 24.

To listen to the sound from external equipment, press **AUX**.

The unit automatically turns on (when the unit is on standby), and “AUX IN” appears on the display.

• For operating external equipment, refer also to its manual.

Adjusting the Volume

You can adjust the volume level only while the unit is turned on.

- The volume level has no effect on recording.

Press **VOLUME + / -** (or turn **VOLUME + / - control on the front panel**).

- You can adjust the volume level within the range of MIN (silent), 1 to 30, MAX (maximum).
- As you adjust the volume, the display changes its color—no color ↔ blue ↔ purple ↔ pink ↔ red.



For private listening

Connect a pair of headphones to the  PHONES jack on the front panel. The sound will no longer come out of the speakers.

Disconnecting a pair of headphones from the  PHONES jack activates the speakers again.

- The Surround mode (page 19) will be canceled temporarily (“STEREO” will appear on the display).
- The Subwoofer level adjustment (page 16) will be invalid while connecting a pair of headphones.



- DO NOT set the volume to a high level before connecting or putting on headphones.
- DO NOT turn off (on standby) the unit with the volume set to an extremely high level; Otherwise, the sudden blast of sound can damage your hearing, speakers and/or headphones when you turn on the unit or start playing any source.
REMEMBER you cannot adjust the volume level while the unit is in standby mode.

To turn down the volume level temporarily

On the remote control ONLY:

Press **FADE MUTING**.

The volume level gradually decreases to “MIN.”

To restore the sound, press **FADE MUTING** again.

- Pressing **VOLUME +** or turning **VOLUME + / - control clockwise (to +)** on the front panel also restores the sound.

Changing the Display Brightness

You can dim the display window.

On the remote control ONLY:

Press **DIMMER**.

- Each time you press the button, the display dims and brightens alternately.

Turning Off the Key-touch Tone

If you do not want the key-touch tone, you can deactivate it.

Press **BEEP ON/OFF** (or press and hold **BEEP** on the front panel).

- Each time you press the button, the key-touch tone turns on and off alternately.

When you deactivate the key-touch tone, the BEEP ON indicator goes off from the display.

Adjusting the Front Speaker Output Balance

You can adjust the output balance of left front speaker and right front speaker.

On the remote control ONLY:

1 Press **LEVEL SELECT** repeatedly until “L/R” appears on the display.

2 Press **LEVEL + / -**.

Adjust the output balance appropriately from the listening point within the range of R (Right) -6 (minimum sound level from the right speaker) to L (Left) -6 (minimum sound level from the left speaker).

Reinforcing the Bass Sound

These function only affect the playback sound, but does not affect your recording.

■ To enjoy heavy sound

You can enjoy heavy sound by using Sound Turbo. This function boosts the low and high frequency sound.

- Activating Sound Turbo cancels the Sound mode and/or Subwoofer level adjustment.

Press **SOUND TURBO**.

The **SOUND TURBO** indicator lights up on the display. The Subwoofer level increases to the maximum level (S.WOOFER 4).

- Each time you press **SOUND TURBO**, Sound Turbo is turned on (S.WOOFER 4) or off (S.WOOFER 1).

■ To change the Subwoofer level precisely

You can select one of the 5 Subwoofer levels—S.WOOFER 0 (MIN LEVEL), S.WOOFER 1 through S.WOOFER 4 (MAX LEVEL).

On the remote control:

1 Press **LEVEL SELECT** repeatedly until “S.WOOFER” appears on the display.

2 Press **LEVEL + / -**.

- To increase the Subwoofer level, press **LEVEL +**.
- To decrease the Subwoofer level, press **LEVEL -**.

On the front panel:

Press **SUBWOOFER LEVEL + / -**.

The **SUBWOOFER** indicator lights up when S.WOOFER 1 to S.WOOFER 4 is selected. The **SUBWOOFER** indicator turns off when S.WOOFER 0 is selected (no effect).



If you press **SUBWOOFER LEVEL + / -** during activating Sound Turbo

Sound Turbo is canceled.



While connecting a pair of headphones

The Subwoofer level adjustment will be invalid.

Selecting the Sound Modes

You can select one of the 3 preset SEA—Sound Effect Amplifier—modes and 3 user modes. This function only affects the playback sound (front left and right channel only), but does not affect your recording.

Press **SOUND MODE** repeatedly until the preferred sound mode appears on the display.

- When one of the Sound modes is selected, the **SOUND MODE** lamp flashes.



- Each time you press **SOUND MODE**, the Sound modes change as follows:

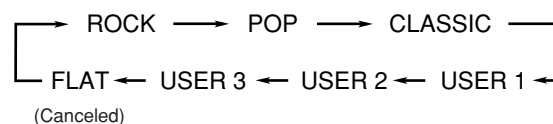

When you press **SOUND MODE** once

You can confirm the Sound mode currently chosen.

SEA (Sound Effect Amplifier) modes

ROCK: Boosts low and high frequency. Good for acoustic music.

POP: Good for vocal music.

CLASSIC: Good for classical music.

User modes

USER 1/2/3: Your individual mode stored in memory. See “Creating Your Own Sound Mode—User Mode” on page 17.

FLAT: The Sound mode is canceled.



While Sound Turbo is activated

The Sound mode is canceled.

Basic Operations (continued)

Creating Your Own Sound Mode—User Mode

You can change the SEA pattern to suit your preference. The SEA pattern can be adjusted using 3 frequency ranges—BASS, MID (middle), and TRE (treble). These changed settings can be stored as the USER 1, USER 2, and USER 3 modes.

- There is a time limit in doing the following steps. If the setting is canceled before you finish, start from step 1 again.

On the front panel ONLY:

1 Select one of the preset Sound modes.

See “Selecting the Sound Modes” on page 16.

2 Press SET/DISPLAY while the selected Sound mode is still shown on the display.

SEA CONT



BASS +3

Current level appears.

3 Adjust the SEA pattern.

- (1) Turn ►►/◄◄ to select the frequency range (BASS, MID or TRE).
- (2) Press ►► / ◄◄ to adjust the level of the selected frequency range.
 - For adjusting BASS
Adjust the level within the range of ± 0 to +3.
 - For adjusting MID or TRE
Adjust the level within the range of -3 to +3.
- (3) Repeat steps (1) and (2) to adjust the level of the other frequency ranges.

4 Press SET/DISPLAY again.

USER 1

5 Turn ►►/◄◄ to select one of the user modes (USER 1, USER 2, or USER 3) in which you want to store your SEA pattern.

6 Press SET/DISPLAY again.

MEMORY

The SEA pattern you have created is stored into the user mode selected in step 5.

To use your own sound mode

Select USER 1, USER 2, or USER 3 mode when using the Sound modes. See “Selecting the Sound Modes” on page 16.



When you unplug the AC power cord or if a power failure occurs

The setting will be erased in a few days. If this happens, set the user modes again.

Changing the Scanning Mode

This unit supports the NTSC progressive scanning system (480p*) as well as the conventional interlaced scanning system (480i*).

If your TV has component video jacks and supports progressive scanning system, you can enjoy a high quality picture from the built-in disc player.

- Refer also to the instruction manuals supplied with your TV.
- You can change the scanning mode only when “NTSC” is selected for the color system of this unit. See page 9.
- You cannot select the progressive scanning mode for the PAL system TVs.



Do not change the progressive scanning mode in the following cases:

- When your TV does not support the progressive video input.
- When you have not connected your TV to the unit using a component video cord.

On the remote control ONLY:

Press PROGRESSIVE.

The PROGRESSIVE lamp lights up on the front panel.

- Each time you press the button, the scanning mode changes between “PROGRESSIV (progressive)” and “INTERLACE” alternately.

- Some progressive TVs and High-Definition TVs are not fully compatible with this system. When an incompatible picture is played back, turn off the progressive scanning mode. To check the compatibility of your TV, contact your dealer. All JVC progressive TVs and High-Definition TVs are fully compatible with this system.

* 480p and 480i indicate the number of scanning lines and scanning format of an image signal.

- 480p indicates 480 scanning lines with progressive format.
- 480i indicates 480 scanning lines with interlaced format.

Prohibiting Disc Ejection—Tray Lock

You can prohibit disc ejection from the unit and lock disc trays.

- This operation is possible only when the unit is turned on.

On the front panel ONLY:

To prohibit disc ejection, press any one of ▲ for disc trays while holding down ■. (If any disc tray is opened, close it first.)

“LOCKED” appears for a while on the display, and all disc trays are locked.

LOCKED

To cancel the prohibition and unlock the disc tray, press any one of ▲ for disc trays while holding down ■.

“UNLOCKED” appears for a while on the display, and all disc trays are released.

UNLOCKED



If you try to eject a disc while Tray Lock is in use

“LOCKED” appears to inform you that the disc trays are locked.

Using Surround Mode

The buttons emphasized in the illustration below are used and explained in the following section (pages 19 and 20).

Remote Control

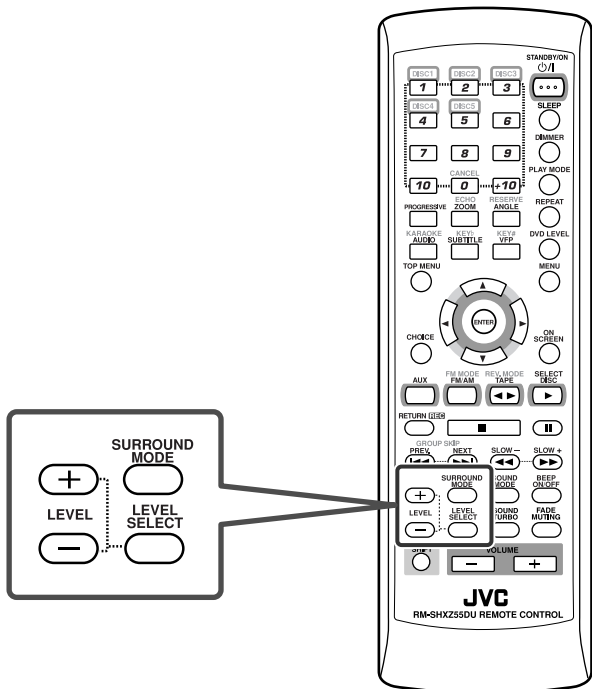

Front Panel

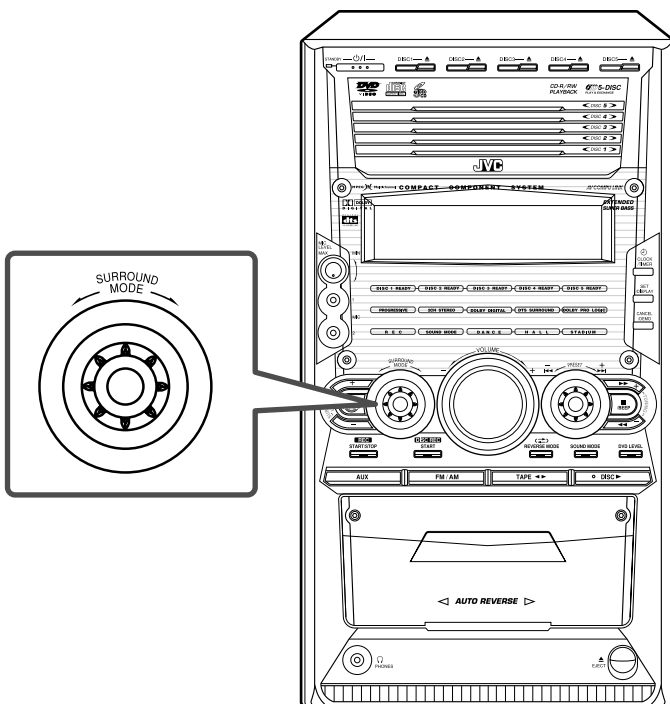

Using Surround Mode (continued)

Available Surround Modes

You can use the following Surround modes to reproduce a realistic sound field:

- To obtain the best possible surround effect, make sure that you have set the speakers' distance information correctly (see pages 12 and 63).
- For details of each Surround mode, see "Glossary" on page 69.

■ Digital multi-channel surround

- Dolby Digital*
- DTS Digital Surround**

■ Dolby surround

- Dolby Pro Logic**

■ Digital Signal Processor (DSP) modes

- DANCE
- HALL
- STADIUM

* Manufactured under license from Dolby Laboratories. "Dolby", "Pro Logic", and the double-D symbol are trademarks of Dolby Laboratories.

** "DTS," and "DTS Digital Surround" are registered trademarks of Digital Theater Systems, Inc.



When you playback MPEG Multichannel software

It can be played back as a 2-channel source. To apply the Surround mode, select "Dolby Pro Logic" or one of the DSP modes.

- To reproduce it with its original MPEG Multichannel surround, connect an MPEG Multichannel decoder to the OPTICAL DIGITAL OUTPUT terminal on the rear.

Playable Surround mode

Available Surround modes vary depending on the source to play.

■ For all 2-channel sources (digital and analog)—including FM/AM, TAPE, and AUX

- DANCE
- HALL
- STADIUM

■ For all discs

- Digital multi-channel surround (Dolby Digital or DTS Digital Surround) depending on the encoding format.
- Dolby Pro Logic
- DANCE
- HALL
- STADIUM

Activating Surround Mode

You can activate the Surround mode automatically depending on the software type and the SURROUND SETTING (see page 62).

- When playing back 2-channel software with the SURROUND SETTING set to "ON."
- When playing back multi-channel software with the SURROUND SETTING set to "AUTO" or "ON."

Press SURROUND MODE (or turn SURROUND MODE control on the front panel).

The SURROUND indicator lights up on the display.

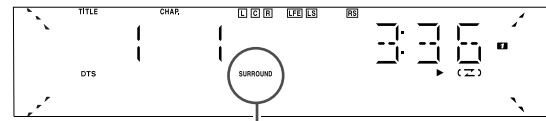

SURROUND indicator

When multi-channel digital disc is played back:

- With the SURROUND SETTING set to "AUTO" or "ON," an appropriate Surround mode is selected automatically, and the corresponding indicator lights up on the display.
 - You cannot select other Surround mode or turn off the Surround mode.

Surround mode	Indication on the display
Dolby Digital	DOLBY D
Dolby Pro Logic	DOLBY PL
DTS Digital Surround	DTS

- With the SURROUND SETTING set to "OFF," the multi-channel signal is mixed down to 2-channel signals. You can select one of the DSP modes. Each time you press SURROUND MODE (or turn SURROUND MODE control on the front panel), the DSP modes change as follows:

On the remote control:

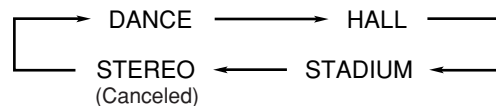

On the front panel:

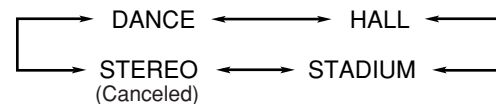

When you playback a DTS-CD

DTS Digital Surround is activated.



When connecting a pair of headphones

The Surround mode will be canceled temporarily ("STEREO" will appear on the display).

When 2-channel source is played back:

- With the **SURROUND SETTING** set to “ON,” Dolby Pro Logic is selected automatically, and the **DOLBY PL** indicator lights up on the display.
 - You cannot select other Surround mode or turn off the Surround mode.
- With the **SURROUND SETTING** set to “AUTO” or “OFF,” one of the DSP modes will be activated.
 - You can select another DSP mode by pressing **SURROUND MODE** repeatedly (or turning **SURROUND MODE** control on the front panel). Each time you press **SURROUND MODE** (or turn **SURROUND MODE** control on the front panel), the DSP modes change as follows:

On the remote control:

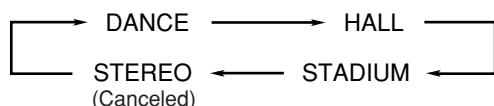

On the front panel:

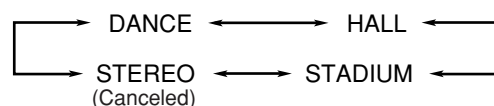

To cancel the Surround mode

Press **SURROUND MODE** (or turn **SURROUND MODE** control on the front panel) until “STEREO” appears on the display.



When connecting a pair of headphones

The Surround mode will be canceled temporarily (“STEREO” will appear on the display).

Adjusting DSP Modes and Output Sound

When playing back a source with the DSP mode, you can adjust the effect levels.

Once you have made an adjustment, it is memorized.

■ Effect level

On the remote control ONLY:

1 Select and play back a disc you like.

When multi-channel source is played back, you cannot select the DSP modes.

2 Activate and select one of the DSP modes.

3 Press **LEVEL SELECT** to select “EFFECT.”

- Each time you press the button, the adjustable item changes as follows:

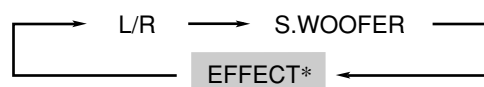

- * Selectable only when one of the DSP modes (DANCE, HALL, STADIUM) is selected.

4 Press **LEVEL +** or **–** to adjust the effect level.

You can select one of the 3 effect levels—EFFECT 1 (less effective), EFFECT 2, or EFFECT 3 (most effective).

- To increase the level, press **LEVEL +**.
- To decrease the level, press **LEVEL –**.

Input signal indicators on the display

By checking the following indicators, you can easily confirm which signals are played back with this disc player.

- Input signal indicators light up only when a DVD or a DTS-CD is played back.

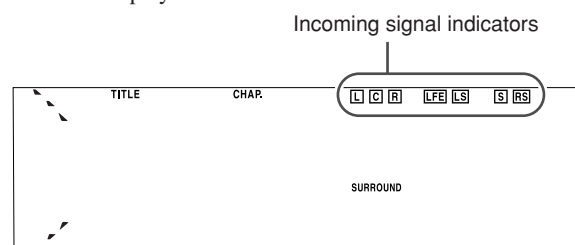

The signal indicators light up to show the incoming signals:

- L:** Light up when the signals corresponding to L (left) channel comes in.
- R:** Light up when the signals corresponding to R (right) channel comes in.
- C:** Lights up when the center channel signal comes in.
- LFE:** Lights up when the LFE* channel signal comes in.
- LS:** Lights up when the left surround channel signal comes in.
- RS:** Lights up when the right surround channel signal comes in.
- S:** Lights up when the monaural surround channel signal comes in.

* LFE stands for low frequency effect. LFE channel signal comes out of front main speakers or the front subwoofer.

Listening to FM and AM Broadcasts

The buttons emphasized in the illustration below are used and explained in the following section (page 22).

Remote Control

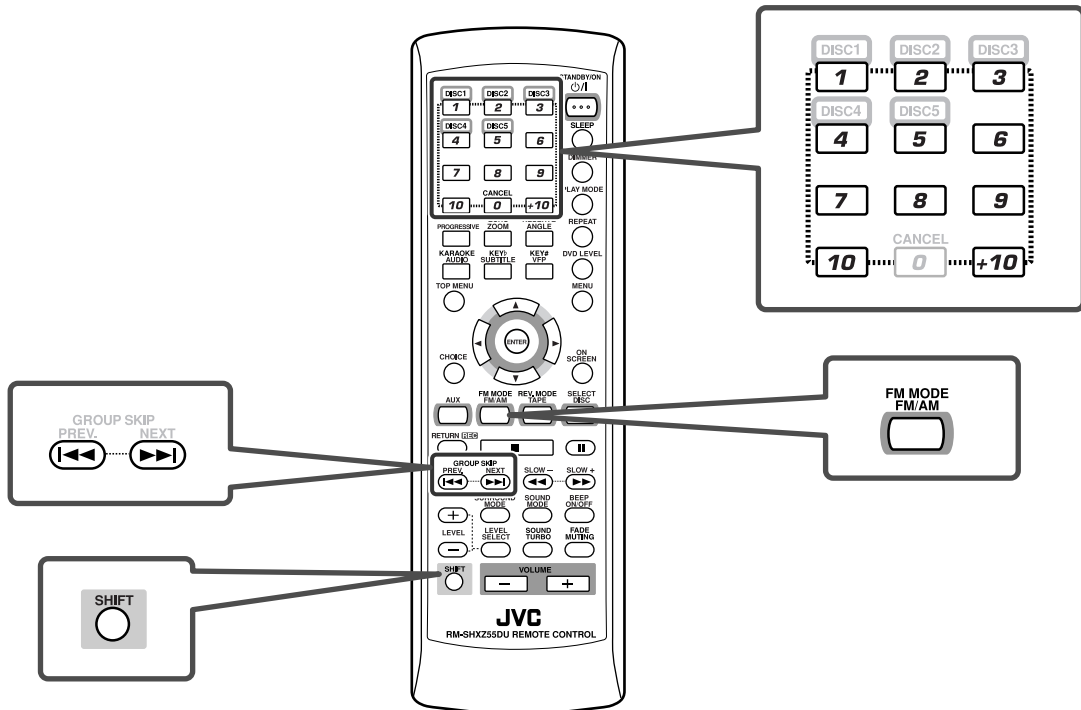

Front Panel

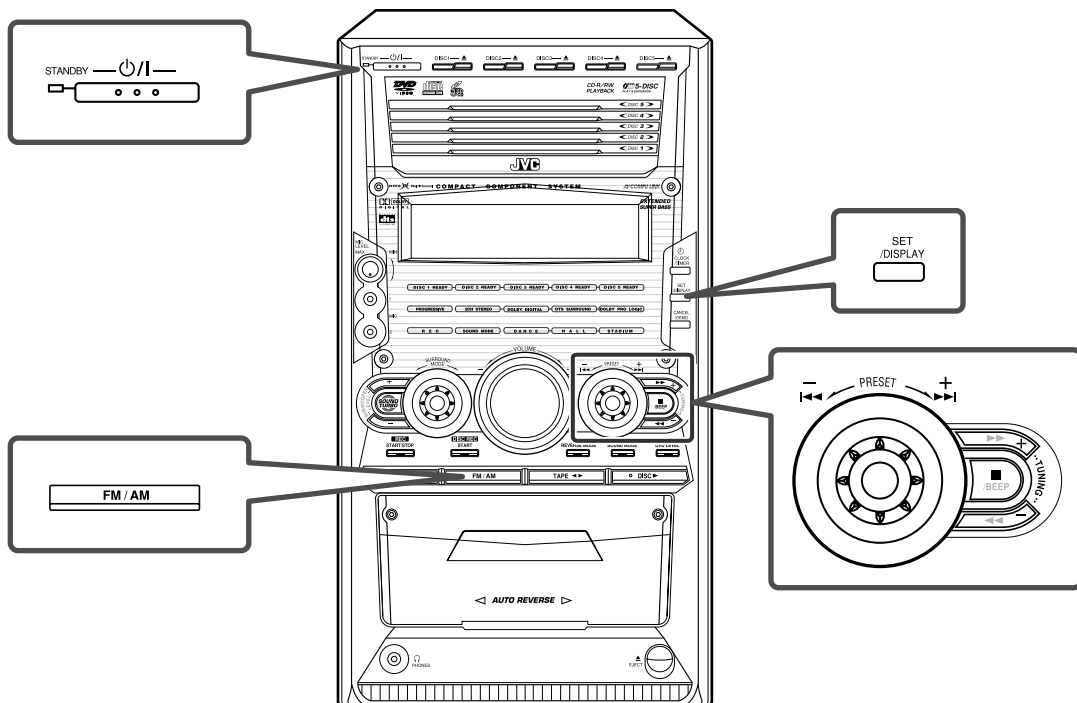

Setting the AM Tuner Interval Spacing

Some countries space AM stations 10 kHz apart, and some countries space 9 kHz apart.

- You can only change the AM tuner interval spacing while tuning in to an AM station. (9 kHz is the initial setting.)

On the front panel ONLY:

1 Press FM/AM repeatedly to select AM.

2 Press  while holding down .

- Each time you press the button, the AM tuner interval spacing alternates between 10 kHz and 9 kHz.

Tuning in to a Station



1 Press FM/AM.

The unit automatically turns on and tunes in to the previously received station (either FM or AM).

- Each time you press the button, the band alternates between FM and AM.

2 Start searching for stations.

On the remote control:

Press and hold  or  for more than 1 second.

On the front panel:



Press and hold TUNING + or TUNING – for more than 1 second.

The unit starts searching for stations and stops when a station of sufficient signal strength is tuned in.

- If a program is broadcast in stereo, the ST (stereo) indicator lights up.

To stop searching, press  /  (or TUNING + or TUNING – on the front panel).



When you press  /  (or TUNING + or TUNING – on the front panel) briefly and repeatedly

The frequency changes step by step.

To change the FM reception mode

On the remote control ONLY:

When an FM stereo broadcast is hard to receive or noisy, press FM MODE while holding down SHIFT so that the MONO indicator lights up on the display. Reception will improve.

To restore the stereo effect, press FM MODE while holding down SHIFT again so that the MONO indicator goes off. In this stereo mode, you can hear stereo sounds when a program is broadcast.

Presetting Stations

You can preset 30 FM and 15 AM stations.

In some cases, test frequencies have been already memorized for the tuner since the factory examined the tuner preset function before shipment. This is not a malfunction. You can preset the stations you want into memory by following the presetting method.

- There is a time limit in doing the following steps. If the setting is canceled before you finish, start from step 2 again.

On the front panel ONLY:

1 Tune in to the station you want to preset.

- See “Tuning in to a Station.”

2 Press SET/DISPLAY.



3 Turn PRESET + / – to select a preset number.



4 Press SET/DISPLAY again.



The tuned station in step 1 is stored in the preset number selected in step 3.

- Storing a new station on a number already used erases the previously stored one.



When you unplug the AC power cord or if a power failure occurs

The preset stations will be erased in a few days. If this happens, preset the stations again.

Tuning in to a Preset Station

1 Press FM/AM.

The unit automatically turns on and tunes in to the previously received station (either FM or AM).

- Each time you press the button, the band alternates between FM and AM.

2 Select a preset number.

On the remote control:

Press the number buttons.

Ex.: For preset number 5, press 5.

For preset number 15, press +10, then 5.

For preset number 25, press +10, +10, then 5.

For preset number 30, press +10, +10, then 10.

On the front panel:

Turn PRESET + / –.

Playing Back Tapes

The buttons emphasized in the illustration below are used and explained in the following section (page 24).

Remote Control

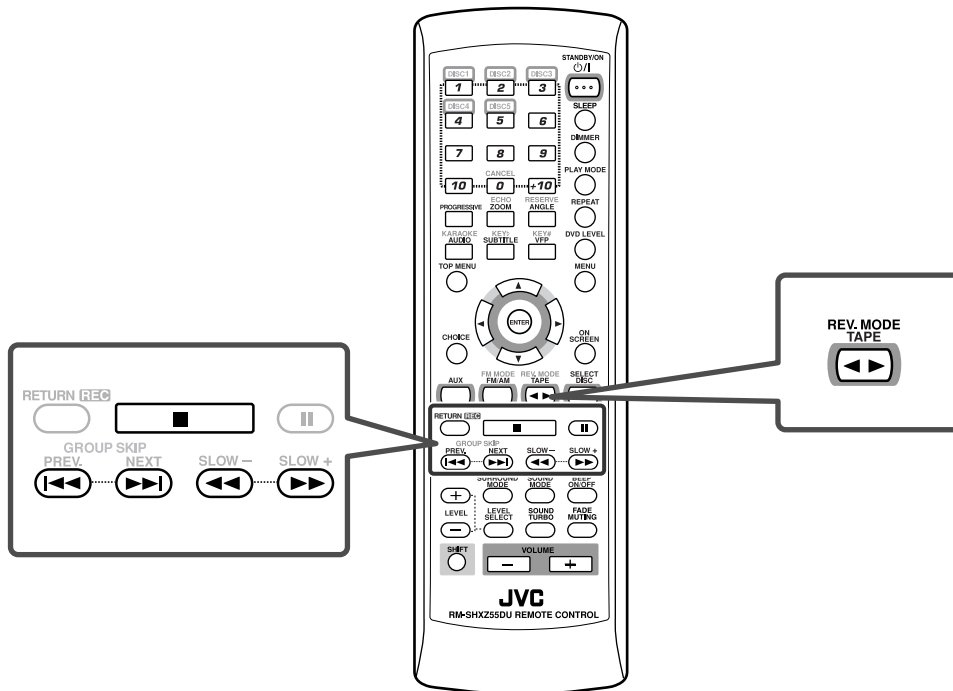

Front Panel

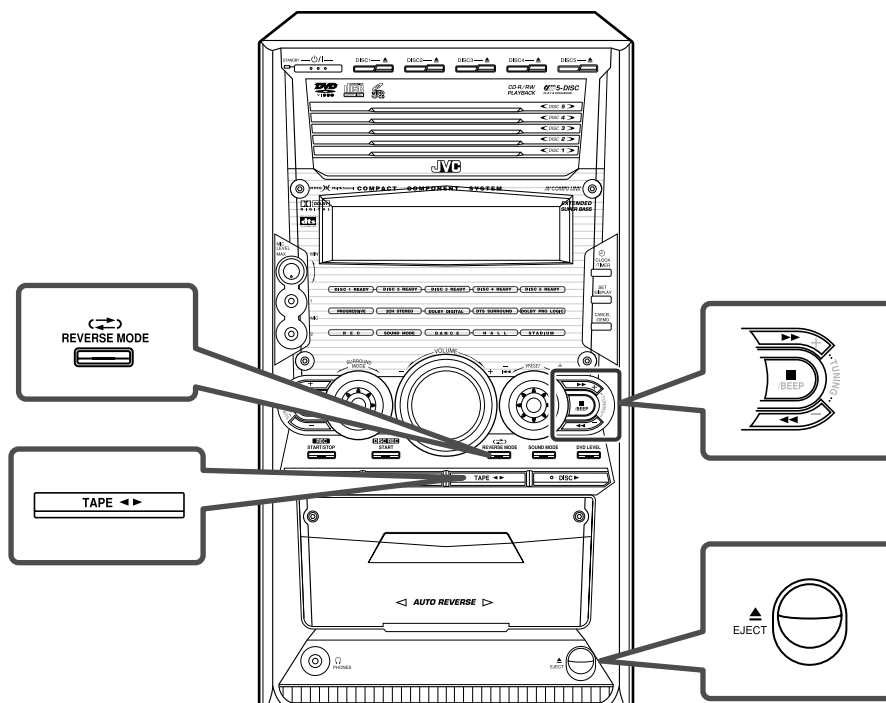

You can play back type I tapes.

Playing Back a Tape

1 Press **EJECT** for the cassette deck.

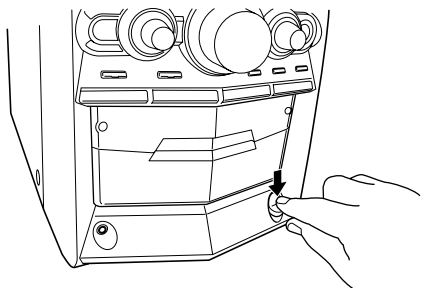

2 Insert a cassette with the exposed part of the tape down.

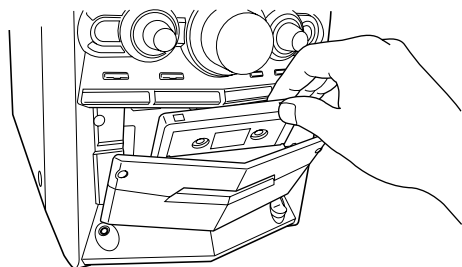

3 Close the cassette holder gently.

4 Press **TAPE** **◀▶**.

The tape play starts and the tape direction indicator (▶ or ◀) starts flashing slowly to indicate the tape's running direction.

- Each time you press the button, "REVERSE" appears for a while on the display and the tape direction changes.
 - ▶: plays the front side.
 - ◀: plays the reverse side.
- If no cassette is inserted, "NO TAPE" appears on the display.

When the tape plays to the end, the deck automatically stops if the Reverse mode is off. (See "To play both sides repeatedly—Reverse mode.")

To stop playing, press **■**.

To fast-wind to the right or to the left, press **▶▶** or **◀◀** while the tape is not running.

The tape direction indicator (▶ or ◀) starts flashing quickly on the display.

- When using the remote control, you can also use **▶▶|/|◀◀**.

To remove the cassette, press **EJECT** to open the cassette holder.

To play both sides repeatedly—Reverse mode

When using the Reverse mode, the tape automatically reverses at the end of one side, starts playing the other side of the tape, and repeats the same process.

On the remote control:

Press **REV. MODE** while holding down **SHIFT**.

On the front panel:

Press **↔ REVERSE MODE**.

The Reverse mode indicator lights up on the display like—**↔**.

To cancel the Reverse mode, press the button again so that the Reverse mode indicator lights up on the display like—**↔**.

Locating the Beginning of a Song—Music Scan

You can use Music Scan to locate the beginning of a song. Music Scan searches for blank portions that usually separate recorded songs, then plays the next song.

■ To find the beginning of the current song

During play, press **▶▶** or **◀◀** in the opposite direction to the tape play.

The tape direction indicator of the opposite direction to the tape play starts flashing intermittently.

Searching stops automatically at the beginning of the current song, and it starts automatically.

- When using the remote control, you can also use **▶▶|/|◀◀**.

■ To find the beginning of the next song

During play, press **▶▶** or **◀◀** in the same direction as the tape is playing.

The tape direction indicator of the same direction as the tape is playing starts flashing intermittently.

Searching stops automatically at the beginning of the next song, and the song starts automatically.

- When using the remote control, you can also use **▶▶|/|◀◀**.



Music Scan works by detecting a 4-second long blank between each song, so it will not work well in the following cases

- No blank at the beginning of a song.
- Noise (often caused by much use or poor quality dubbing) which fills the blank.
- Long, very soft passages or pauses in a song.



The use of C-120 or longer tape is not recommended, since characteristic deterioration may occur and this tape easily jams in the pinch-rollers and the capstans.

Playing Back Discs

The buttons emphasized in the illustration below are used and explained in the following section (pages 26 to 34).

shows the types of discs the operation is available for.

- For MP3 and JPEG disc playback, see pages 44 and 45. (For how to make a program using MP3 discs is explained in this section.)

Remote Control

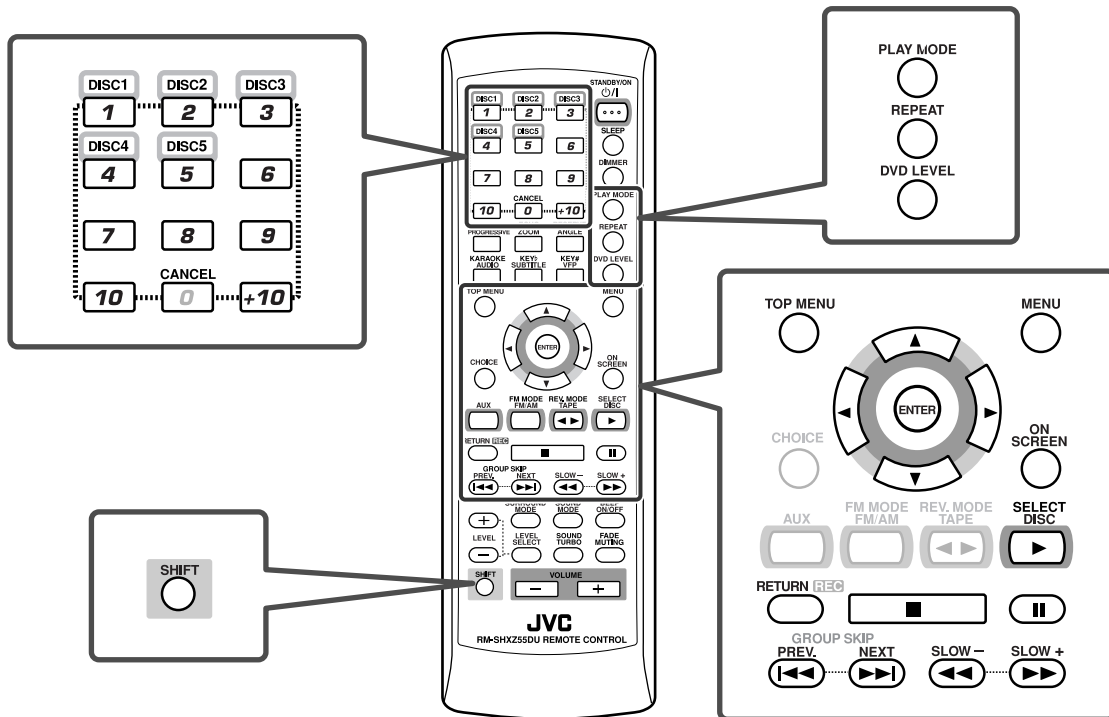

Front Panel

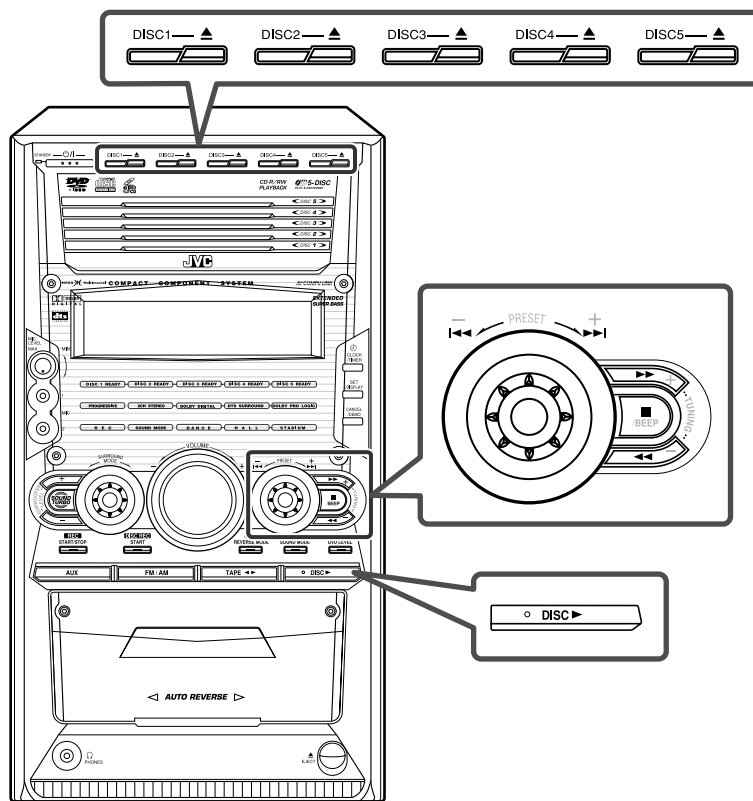







Disc Information

Playable disc types

This unit has been designed to play back the following discs: DVD VIDEO, DVD-R, DVD-RW, Video CD (VCD)*, Super Video CD (SVCD)*, Audio CD*, CD-R, and CD-RW.

* This instruction refers to Video CD as “VCD,” Super Video CD as “SVCD,” and audio CD as “CD.”

Disc Type	Mark (Logo)	Color System
DVD VIDEO		NTSC or PAL
Video CD (VCD)		
Super Video CD (SVCD)		
Audio CD (CD)		—
CD-R		—
CD-RW		—

In addition to the above discs, this unit can play back audio data recorded on CD Text and CD Extra.

- The following discs cannot be played back: DVD AUDIO, DVD-ROM, DVD-RAM, CD-ROM, CD-I (CD-I Ready), CD-G (CD Graphic), Photo CD, etc. Playing back these discs will generate noise and damage the speakers.
- This unit can also play back MP3 and JPEG (still picture) files recorded on CD-R and CD-RW. For details about MP3 and JPEG disc operations, see “MP3/JPEG Disc Playback” on pages 44 and 45.
- On some DVD VIDEO, SVCD or VCD, their actual operations may be different from what is explained in this manual. This is due to the disc programming and disc structure, but not a malfunction of this unit.
- You can play back DVD-R or DVD-RW recorded with the DVD VIDEO format, but some may not be played back because of the disc characteristics or recording conditions.



About Region Code

DVD players and DVD VIDEO have their own Region Code numbers. This unit can play back only DVD VIDEO recorded with the color system of NTSC/PAL whose Region Code number is the same as printed on the rear panel.

For Saudi Arabia, Turkey, Egypt, etc.



For Singapore, Malaysia, Philippine, etc.



If a DVD VIDEO with the wrong Region Code number is loaded, “REGION ERR” appears on the display and playback cannot start.



On CD-R and CD-RW

- User-edited CD-R (Recordable) and CD-RW (ReWritable) can be played back only if they are already “finalized.”
- The unit can play back CD-R or CD-RW recorded on a personal computer if they have been recorded in the CD format or in ISO 9660 format.
- Before playing back CD-R or CD-RW, read their instructions or cautions carefully.
- CD-RW may require a longer readout time. It is caused by the fact that the reflectance of CD-RW is lower than for regular CD.
- The unit can also play back CD-R or CD-RW if MP3 files or JPEG files are recorded on them. However, they may not be played back because of their disc characteristics, recording conditions, or damage or stain on them. Especially, the configuration and characteristics of an MP3 disc or a JPEG disc is determined by the writing (encoding) software and hardware used for recording. Therefore, due to the software and hardware used, the following symptoms may occur:
 - Some discs may not be played back.
 - Some tracks on an MP3 or JPEG disc are skipped and may not be played back normally.
 - Some files on a JPEG disc may be played back distortedly.

About copy protection

This product incorporates copyright protection technology that is protected by method claims of certain U.S. patents and other intellectual property rights owned by Macrovision Corporation and other rights owners. Use of this copyright protection technology must be authorized by Macrovision Corporation, and is intended for home and other limited viewing uses only unless otherwise authorized by Macrovision Corporation. Reverse engineering or disassembly is prohibited.

- The Macrovision’s copy protection system is applied to this unit. If you make a copy on your VCR from a disc that is recorded this copy protection signal, the copy cannot be played back normally.

IMPORTANT: Before playing a disc, make sure of the following....

- Check the connection with the TV.
- Turn on the TV and select the correct input mode on the TV to view the pictures or on-screen indications on the TV screen.
- For disc playback, you can change the initial setting to your preference. (See pages 59 to 66.)

If “⊗” appears on the TV screen when you press a button, the disc cannot accept the operation you have tried to do, or data required for that operation is not recorded on the disc.

NOTICE: In some cases, without showing “⊗,” operations will not be accepted.

To change the color system of this unit, see page 9.

Playing Back Discs (continued)

Disc structure

DVD VIDEO consists of “titles,” and each title may be divided into some “chapters.”

For example, if a DVD VIDEO contains some movies, each movie may have its own **title** number and it may be further divided into some **chapters**. In a DVD VIDEO Karaoke, each song may have its own **title** number, but it may not be further divided into **chapters**.

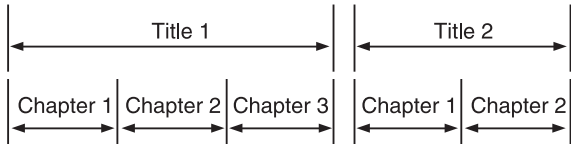

SVCD, VCD, and CD consist of “tracks.”

In general, each track has its own **track** number. (On some discs, each track may also be divided by indexes. This unit is not compatible with Index function.)

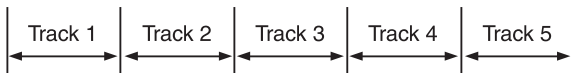

On an **MP3 disc**, each song is recorded as a file. Files are usually grouped into a folder. Folders can also include other folders, creating hierarchical folder layers.

This unit simplifies the hierarchical construction of a disc and manages files and folders by “tracks” and “groups.”

There are following limitations about the numbers of files and of groups this unit can recognize.

- Total number of files on a disc: 1000
- Total number of groups: 99
- Total number of files in each group: 150

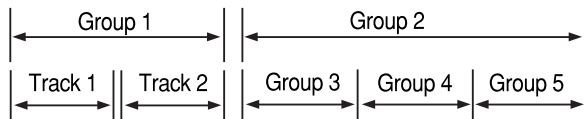

On a **JPEG disc**, each still picture is recorded as a file. Files are usually grouped into a folder. Folders can also include other folders, creating hierarchical folder layers.

This unit simplifies the hierarchical construction of a disc and manages folders by “groups.”

There are following limitations about the numbers of files and of groups this unit can recognize.

- Total number of files on a disc: 1000
- Total number of groups: 99
- Total number of files in each group: 150

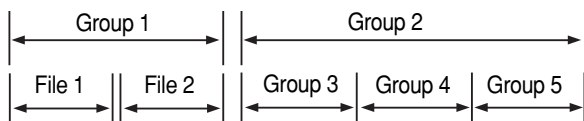

Playback Control function (PBC)—SVCD and VCD only

The Playback Control function enables menu-driven operation.

Menu-driven playback

A selection menu is displayed when you start playing a SVCD and VCD with the Playback Control feature. The selection menu shows a list of numbers for selection. Some discs may show moving pictures or a divided screen. You can interact with the screen using a menu display to select and play an entry.

See the example illustration below about basic feature of menu-driven playback (for details about the operation through the menu, see also page 32).

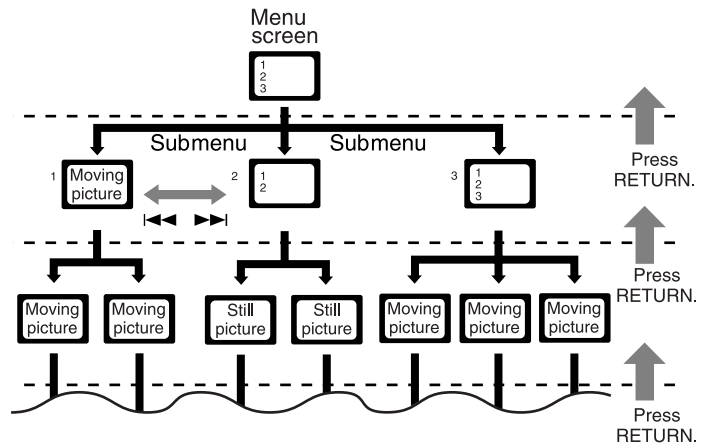

While operating a SVCD or VCD using the menu
Some of the functions such as Repeat Play may not work.

Loading Discs

1 Press \blacktriangle for the disc tray (DISC1 – DISC5) you want to load a disc onto.

The unit automatically turns on and the corresponding disc tray comes out.



2 Place a disc correctly on the circle of the disc tray, with its label side up.

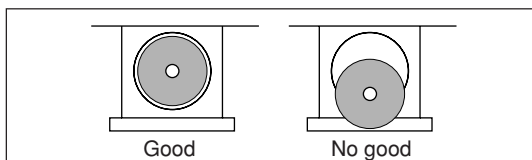

- When using a CD single (8 cm), place it on the inner circle of the disc tray.

3 Press the same \blacktriangle you have pressed in step 1.

Disc tray closes (and playback starts automatically for some discs).

- When you press \blacktriangle for the next tray you want to place another disc onto, the first disc tray automatically closes and then the next tray comes out.

About the DISC READY lamps

Each DISC READY lamp shows the status of a disc placed on each corresponding disc tray (DISC1 – DISC5).

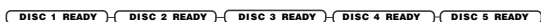

- **DISC READY lamps light up**
When the disc is loaded and currently selected.
- **DISC READY lamps light slightly**
When the disc is loaded, but not currently selected.
- **DISC READY lamp flashes**
When the disc is played back or paused.
- **DISC READY lamps turns off**
When the unit detects there is no disc loaded on a certain tray. (“NO DISC # (number)” appears on the display.)



While display brightness is dimmed (page 16)

Only DISC READY lamp of the selected tray number lights up slightly.

If there is no disc loaded on the selected disc tray, all the DISC READY lamps go off.



If the loaded disc currently selected is an MP3 disc

The corresponding DISC READY lamp and the MP3 indicator will light up.

About the DISC playback indications

Ex. 1: While playing a DVD.

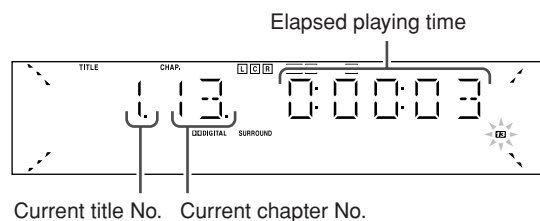

Ex. 2: While playing a SVCD/VCD/CD.

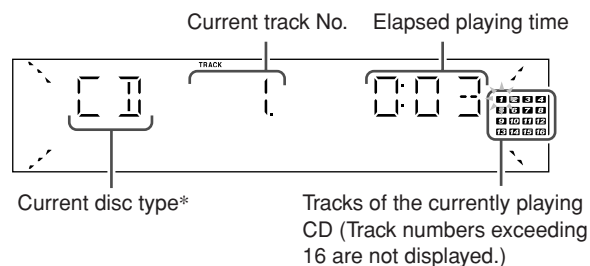

* About the indication of current disc type

- “CD”: shows an CD is loaded.
- “VCD”: shows a SVCD or VCD is loaded.
 - When an SVCD or VCD is loaded with PBC function, “PBC” appears instead of elapsed playing time.

Ex. 3: While playing an MP3.

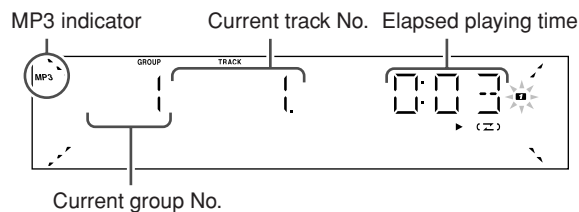

Ex. 4: While playing a JPEG.

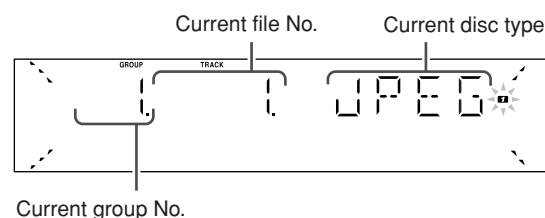

Playing Back Discs (continued)

Continuous Playback



You can play discs continuously.

- Make sure you do not select “REPEAT 1” or “REPEAT 1 DISC” to operate this function.

1 Load discs.

2 Select the disc to start playing back.

On the remote control:

Press the corresponding disc number button (DISC1 – DISC5) while holding down SHIFT.

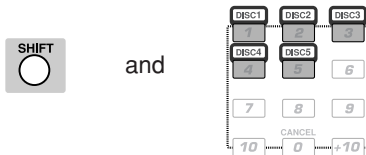

On the front panel:

Press the corresponding disc number button (DISC1 – DISC5).



The unit searches for the disc, and starts playing with the first track of the selected disc.

Disc playback sequence

When more than one disc* are loaded on the disc trays, they are played in the following sequence:

- Ex.:
- When DISC2 is pressed:
DISC2 ⇒ DISC3 ⇒ DISC4 ⇒ DISC5 ⇒ DISC1
(then stops)
 - When DISC5 is pressed:
DISC5 ⇒ DISC1 ⇒ DISC2 ⇒ DISC3 ⇒ DISC4
(then stops)

* When no disc is loaded on the tray, that disc tray is skipped.



Continuous playback does not work for SVCD/VCD with the PBC function and some DVDs

When you play these discs, press ENTER or DISC ►.



When a disc menu appears on the TV screen

See “Playing Back by Using the Disc Menu” on page 32.

To stop play for a moment, press II.

While pausing, the elapsed playing time and the disc indicator flash on the display.

- To start playback again, press DISC ►.

To stop playing, press ■.

- This unit can store the stop point, and when you start playback again by pressing DISC ►, playback starts from the position where you have stopped—Resume Play. (“RESUME” appears on the display.)

To use Resume Play, you need to turn on the Resume function. (See page 63.)

- The Resume function does not work for CDs, MP3 and JPEG discs.
- When using the Resume function on SVCD or VCD with PBC, the playback might start on a position slightly different from where you have stopped.
- To stop completely when you use the Resume function, press ■ twice.



When you select another disc tray

The stored position where you have stopped will be erased.

Changing the Disc to Play Back

While playing a disc, you can select and play back the disc.

To select a disc to play back

On the remote control:

Press the corresponding disc number button (DISC1 – DISC5) while holding down SHIFT.

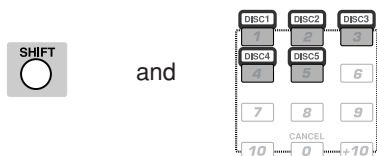

On the front panel:

Press the corresponding disc number button (DISC1 – DISC5).

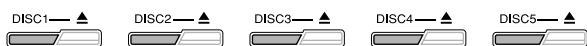

The disc on the selected disc tray is played back.

To exchange discs during playback of another disc

On the front panel ONLY:

1 Press  for the disc tray (DISC1 – DISC5) you want to load a disc onto.

Select the disc which is not playing or selected currently, to exchange the disc.

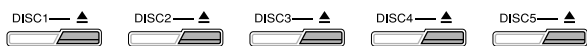

- When you exchange the disc currently played back, playback stops.

2 Press the same  you have pressed in step 1.

Disc tray closes.

You can play back all loaded disc in sequence except when it is in Repeat Play. (See page 32.)

- To play back the disc you have just loaded, press the corresponding disc number button.



If you press disc number button when the corresponding disc tray is open

The disc tray closes and playback starts if a disc is ready.



Basic Disc Operations

For details about MP3/JPEG discs playback, see pages 44 and 45.

To go to another chapter



Press  or  during playback.

- : Skips to the beginning of the next or succeeding chapters.
- : Goes back to the beginning of the current or previous chapters.



If you cannot skip chapters

Some DVDs or some scenes on DVD will not accept this operation.

To go to a particular title or chapter directly using the number buttons



On the remote control ONLY:

- Pressing the number buttons **before playback** allows you to start playing with the title number you want.
- Pressing the number buttons **during playback** allows you to start playing with the chapter number of the currently playing title you want.
 - Ex.: To select number 5, press 5.
 - To select number 10, press 10.
 - To select number 20, press +10, then 10.
 - To select number 23, press +10, +10, then 3.









If a menu is shown on the TV while playing a DVD

Number buttons may be used for selecting an item in the menu. (See page 32.)

To go to another track







Press  or  (or turn  /  on the front panel) during playback.

- : Skips to the beginning of the next or succeeding tracks.
- : Goes back to the beginning of the current or previous tracks.



While playing a SVCD or VCD with the PBC function

 and  (or  /  control on the front panel) may be used for moving another menu. (See page 32.)

Playing Back Discs (continued)

To go to a particular track directly using the number buttons



On the remote control ONLY:

Pressing the number buttons before or during playback allows you to start playing with the track number you want.

- Ex.: To select number 5, press 5.
 To select number 10, press 10.
 To select number 20, press +10, then 10.
 To select number 23, press +10, +10, then 3.



While playing a SVCD or VCD with the PBC function

Number buttons may be used for selecting an item in the menu. (See page 32.)

To search for a particular point



You can search for a particular portion while playing a disc—Forward/Reverse Search.

- Press ►► or ◀◀ during playback. Each time you press ►► (or ◀◀), the unit forwards (or reverses) playback, changing the playback speed as follows:

x2 ⇒ x5 ⇒ x10 ⇒ x20 ⇒ x60

Pressing DISC ► resumes normal playback.



During Forward/Reverse Search

When playing a DVD, SVCD, or VCD disc, no sound comes out during Forward/Reverse Search.

To show the on-screen indication



You can show the following information on the TV while playing back a disc.

On the remote control ONLY:

To show the on-screen indication, press ON SCREEN while playing a disc.

Ex.: When DVD is a playing source.



Ex.: When SVCD/VCD/CD is a playing source.



- ①: Disc type
- ②: The disc tray number of the current disc.
- ③: For DVD: Current title number.
For SVCD/VCD/CD: Current track number.
- ④: Current chapter number.
- ⑤: Various time indications.

When you press ON SCREEN twice, the pull-down menu will appear on the TV. For details, see “About the On-screen Bar” on page 36.

To erase the on-screen indication, press ON SCREEN repeatedly until it goes off.

To increase the sound level for DVD playback automatically



The DVD's audio sound is sometimes recorded at a lower level than for other discs such as VCDs or CDs.

If you have adjusted the volume level for a DVD, the output sound may be unexpectedly loud when you start playing back a disc other than DVD.

To avoid this inconvenience, this unit is preset to increase the sound level for DVD playback automatically—the initial setting is “DVD LEVEL +.”

- Once you have set this function, it is effective every time you play back a DVD.
- This function does not affect any discs other than DVDs.
- This function does not affect the audio output level through the OPTICAL DIGITAL OUTPUT terminal.

To turn on and off the function, press DVD LEVEL.

- Each time you press the button, the setting alternates between “DVD LEVEL +” (on) and “DVD NORMAL” (off).

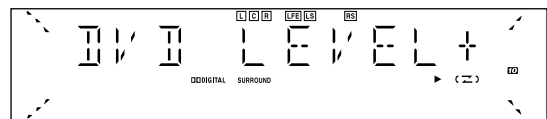

Playing Back by Using the Disc Menu



Some DVDs are recorded with their own menus which show their contents. SVCDs or VCDs with the Playback Control (PBC) function also have their own menus, such as lists of songs. You can play back the discs by using these menus.

■ When playing a DVD

DVD discs generally have their own menus which show the disc contents. These menus contain various items such as titles of movies, names of songs, or artist information, and display them on the TV.

On the remote control ONLY:

1 Press TOP MENU or MENU.

The menu appears on the TV.

Ex.:

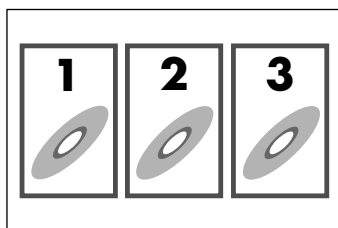

Normally, a DVD containing more than one title will list the titles in a title menu. Press TOP MENU to show the title menu. Some DVD discs may also have a different menu which is shown by pressing MENU.

- See the instructions of each DVD disc for its particular menu.

2 Use cursor ◀/▶/▲/▼ to select a desired item, then press ENTER.

Playback of the selected item starts.

- With some discs, you can also select items by entering the corresponding number using the number buttons.
- You can press SELECT (DISC ▶) instead of ENTER.

■ When playing a SVCD or VCD

The Playback Control function (PBC) allows you to operate the SVCD or VCD by using menus.

When a SVCD or VCD with the PBC is detected, “VCD PBC” appears on the display.

When you start playback, a menu automatically appears on the TV screen.

- A menu may be a list of items, divided screens, or some moving pictures. (See “Playback Control function (PBC)—SVCD and VCD only” on page 27.)
- See also the instructions of each disc for its particular menu.

Ex.:

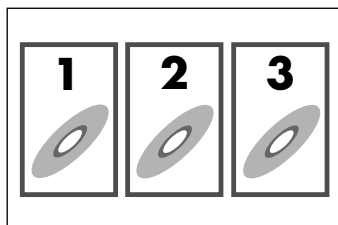

On the remote control ONLY:

To select the number of the desired item, press the number buttons.

- Ex.:
- To select number 5, press 5.
 - To select number 10, press 10.
 - To select number 20, press +10, then 10.
 - To select number 23, press +10, +10, then 3.

Playback of the selected item starts.

To return to the previous menu, press RETURN or DISC ▶.

When “NEXT” or “PREVIOUS” is shown on the menu:

You can go to other pages of the menu.

- To go to the next page, press NEXT (▶▶).
- To return to the previous page, press PREV. (◀◀).

To cancel the PBC function

- 1 Press ■ during playback.
Playback stops. (“VCD RESUME” appears on the display.)
- 2 Press the number buttons to select the track number you want to play.
Playback starts from the selected track without the PBC function.

To activate the PBC function again, press ■ twice to show “VCD PBC” on the display, then press DISC ▶.

Repeating Playback —Repeat Play



You can repeat playback of the current title or chapter (for DVD), or track.

- You can also select Repeat Play using on-screen bar. (See page 37.)

- For DVD/SVCD/VCD: **During playback**
- For CD: **During playback or while stopped**

On the remote control ONLY:

Press REPEAT during play.

- Each time you press the button, Repeat Play mode changes as follows:

For DVD:

CHAP (chapter) ⇒ TITLE ⇒ ALL ⇒ OFF ⇒
(back to the beginning)

For SVCD/VCD/CD:

TRACK ⇒ DISC ⇒ ALL ⇒ OFF ⇒ (back to the beginning)

Playing Back Discs (continued)

CHAP (chapter)	Repeats the current chapter (the REPEAT 1 indicator lights up on the display)
TRACK (STEP*)	Repeats the current track (the REPEAT 1 indicator lights up on the display) * "STEP" appears during Program Play or Random Play.
TITLE	Repeats the current title (the REPEAT indicator lights up on the display)
DISC	Repeats all tracks on the current disc (the REPEAT 1DISC indicator lights up on the display)
ALL	Repeats all the discs loaded on the disc trays or of the program (the REPEAT ALL indicator lights up on the display)
OFF	Select to cancel Repeat Play mode.

To stop playing, press ■.

To cancel Repeat Play, press REPEAT repeatedly until Repeat Play mode indicators are turned off on the display.

- Pressing ■ during Repeat Play of DVD stops playback and cancels Repeat Play.
- Turning off the unit will also cancel the Repeat Play.



While playing a SVCD or VCD with the PBC function

When the PBC function is activated, Repeat All may not work properly.

Programming the Playing Order—Program Play

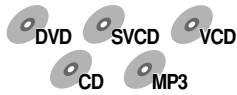

You can arrange the playing order in which the chapters/tracks/files are played back before you start playing.

- You can program up to 99 steps.
- Program Play may not be able to use with JPEG discs and some DVDs.

On the remote control ONLY:

There is a time limit in doing the following steps. If the setting is canceled before you finish, start from step 2 again.

- 1** Load discs.
- 2** Press the corresponding disc number button (DISC1 – DISC5) while holding down SHIFT for which you have loaded a disc, then press ■.

3 Press PLAY MODE repeatedly until “PROGRAM” appears on the display.

- Each time you press the button, the play mode changes as follows:

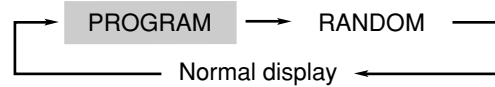

The PROGRAM indicator also lights up on the display.



- If a program has been stored in memory, the previous program is called up.

4 Press the number buttons to select a disc tray.

The selected disc number Chapter/track number

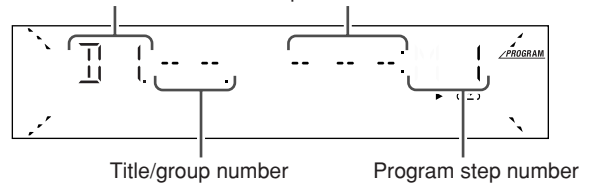

5 For DVD, MP3 disc:

- (1)** Press the number buttons to select a title (for DVD) or a group (for MP3) from the selected disc in step 4.

- After entering a title or group number, chapter/track number area will flash.
- For how to use the number buttons, see “To go to a particular title or chapter directly using the number buttons” on page 30.

- (2)** Repeat step (1) to select a chapter (for DVD) or a file (for MP3).

For SVCD, VCD, or CD:

- Press the number buttons to select a track from the selected disc in step 4.**

- When you program a track from an SVCD, VCD, or CD, you can skip the group/title number by pressing ENTER.
- For how to use the number buttons, see “To go to a particular track directly using the number buttons” on page 31.

6 Repeat steps 4 and 5 to program other tracks you want.

7 Press DISC ►.

The tracks are played in the order you have programmed.



While Random Play (page 34) is activated
You cannot use Program Play.



To use Repeat Play (page 32) for Program Play
Press REPEAT after starting Program Play. Only REPEAT 1 or REPEAT ALL can be selected for Program Play.

To stop playing, press ■.

Playback stops, but Program Play is still activated.

- To exit from Program Play, see “To exit from Program Play” below.

To go to the next step, press ►►.



If your entry is ignored

You have tried to program a title/track/group number that does not exist on the disc (for example, selecting track 14 on a disc that only has 12 tracks). Such entries are ignored, and are erased from the program.

To check the programmed contents

On the TV:

- Before or after playback**

Press PLAY MODE.

- During playback**

Press ■.

The programmed contents appear on the TV.

To erase the play mode screen, press PLAY MODE again.

PROGRAM			
No.	Disc	Group/Title	Track/Chapter
1	3	5	1
2	5	5	6
3	2	8	12
4	1	2	7
5			
6			
7			
8			
9			
10			

USE NUMERIC KEYS TO PROGRAM TRACKS.
USE CANCEL TO DELETE THE PROGRAM.

On the display:

Press ►►/◄◄ (or turn ◄◄/►► on the front panel) while Program Play is stopped.

- ►►: Shows the programmed tracks in the programmed order.
- ◄◄: Shows them in the reverse order.

To modify the program

You can modify the program before or after playing.

To erase the last step, press CANCEL while holding down SHIFT.

- Each time you press CANCEL, the last programmed step is erased.

To add steps in the program before play, simply select the numbers you want to add by pressing the number buttons.

To erase the entire program, press ■ before or after playback.

- Turning off the unit will also erase the program.

To exit from Program Play

Press PLAY MODE repeatedly until the PROGRAM indicator goes off from the display before or after playback.

Playing at Random —Random Play

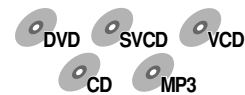

You can play disc's contents at random.

- Random Play cannot be used on some DVD discs.
- If a JPEG disc is loaded, it is not played back during Random Play.

On the remote control ONLY:

1 Load discs.

2 Press PLAY MODE repeatedly until “RANDOM” appears on the display.

- Each time you press the button, the play mode changes as follows:

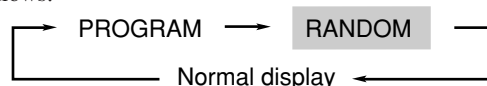

The RANDOM indicator also lights up on the display.

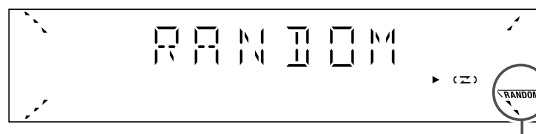

RANDOM indicator

3 Press DISC ►.

Playback starts in a random order.

Random Play ends when all the contents are played once.

To skip the current playing item, press ►► (or turn ◄◄/►► on the front panel clockwise).

- You cannot go back to the previous chapter, track, or file in Random Play.

To stop playing, press ■.

Playback stops, but Random Play is still activated.





To exit from Random Play

Press PLAY MODE repeatedly until the RANDOM indicator goes off from the display before or after playback.

- Turning off the unit will also cancel Random Play.

Advanced Disc Operations

The buttons emphasized in the illustration below are used and explained in the following section (pages 36 to 45).

    shows the types of discs the operation is available for.

Remote Control

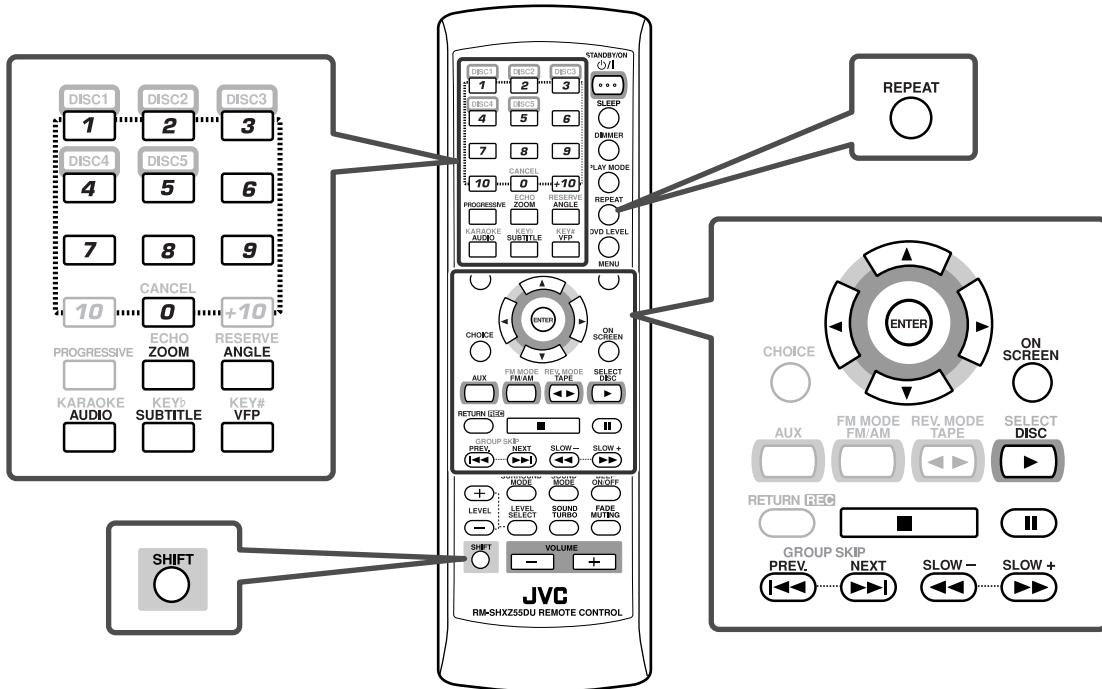

This section explains advanced disc operations by using the remote control.

For MP3 and JPEG playback, see pages 44 and 45.

- See also “Basic Disc Operations” on pages 30 and 31.
- Turn on your TV and select the correct input mode on the TV.

If “” appears on the TV when you press a button, the disc cannot accept an operation you have tried to do, or data required for that operation is not recorded on the disc.

About the On-screen Bar



You can check the information on a disc while the disc is loaded and use some functions through the on-screen bar.

- Whenever a disc is loaded with the disc player selected as the source

Press ON SCREEN.

- Each time you press the button, the on-screen bar changes as follows:

Ex.: While playing a DVD.

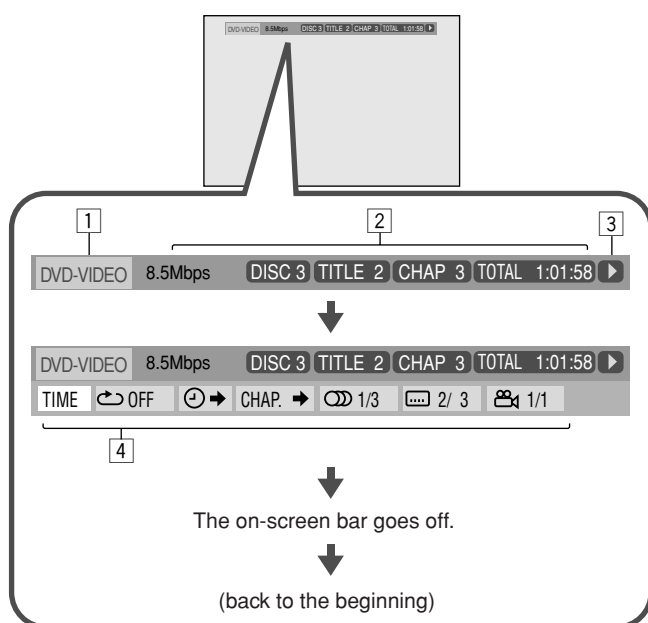

- For the contents of the on-screen bar (1 to 4), see the right column.

On-screen guide icons

- During disc playback, the following guide icons may appear for a while on the TV:
 - : appears at the beginning of a scene containing multi-angle views.
 - : appears at the beginning of a scene containing multi-audio languages.
 - : appears at the beginning of a scene containing multi-subtitle languages.
- “▶” (Play), “||” (Pause), “▶▶” (Forward Search), “◀◀” (Reverse Search), “▶▶▶” (Forward slow-motion), “◀◀◀” (Reverse slow-motion): appears when you perform each operation.
- If you do not want the on-screen guide icons, see page 63.

- 1 Disc type
- 2 Playback information

Indication	Meanings	Available discs
Mbps	shows the current transfer rate (Megabits per second).	DVD
DISC 3	shows the the current disc number	DVD, SVCD, VCD, CD
TITLE 2	shows the current title.	DVD
CHAP 3	shows the current chapter.	DVD
TRACK 14	shows the current track.	SVCD, VCD, CD
TOTAL 1:25:58	shows the time indications.	all discs

- 3 Playback conditions

Indication	Meanings
	Playback
	Forward/Reverse Search
	Forward/Reverse slow-motion
	Pause
	Stop

- 4 Operation icons (on the pull-down menu)

Indications	Meanings	Available discs
	Select to change the time indication. See page 37.	all discs
	Select to repeat playback. See page 39.	all discs
	Select for time search. See page 38.	DVD, VCD, CD
	Select for chapter search. See page 38.	DVD
	Select to change the audio language or channel. See page 41.	DVD, SVCD, VCD
	Select to change subtitle language. See page 40.	DVD, SVCD
	Select to change the view angle. See page 40.	DVD

Advanced Disc Operations (continued)

Operation through the On-screen Bar

Ex.: When selecting Repeat Play for DVD.

1 Press ON SCREEN twice.

The on-screen bar with pull-down menu appears on the TV.



2 Press cursor ► / ◀ repeatedly to select (highlight) ◀ on the pull-down menu.



- See the relevant page for the detail of each function.

3 Press ENTER.

The pop-up window appears under the pull-down menu.



4 Press cursor ▼ / ▲ repeatedly to select the desired option in the pop-up window.

- Each time you press the button, the options change.



5 Press ENTER.

The setting changes and the pop-up window goes off.



To turn off the on-screen bar

Press ON SCREEN.

■ Changing the Time Indication



You can change the time information in the on-screen bar and the display window on the front panel.

□ During playback

1 Press ON SCREEN twice.

The on-screen bar with pull-down menu appears on the TV.



2 Press ENTER.

- Each time you press ENTER, the time indication in the on-screen bar changes as follows:

Ex.: When playing a DVD

TOTAL 1:25:58 ⇒ T.REM 0:45:41 ⇒ TIME 0:25:58 ⇒

REM 0:18:14 ⇒ (back to the beginning)

TOTAL	Elapsed disc time
T. (total) REM	Remaining disc time
TIME	Elapsed playing time of the current chapter/track
REM	Remaining time of the current chapter/track

- The indication on the display also changes.

To turn off the on-screen bar

Press ON SCREEN.

■ Locating a desired chapter—Chapter Search

When playing back a disc, you can search for the chapter/track number to play.

□ During playback

1 Press ON SCREEN twice.

The on-screen bar with pull-down menu appears on the TV.



2 Press cursor ► / ◀ repeatedly to select (highlight) CHAP.► on the pull-down menu.



3 Press ENTER.

The pop-up window appears under the pull-down menu.



4 Press the number buttons (0 – 9) to enter the desired chapter/track number.

You can select up to the 99th chapter.

Ex.: To select chapter/track number 8, press 8.
To select chapter/track number 10, press 1, then 0.
To select chapter/track number 37, press 3, then 7.

To correct a misentry

Press the number buttons until the desired number shown in the pop-up window.

5 Press ENTER.

The unit starts playback from the selected chapter.

To turn off the on-screen bar

Press ON SCREEN.

■ Locating a desired position—Time Search

You can start playback at your desired position by specifying the elapsed playing time from the disc.

- Time Search may not work for some DVDs.

- For DVD/VCD: **During playback**
For CD: **During playback or while stopped**

1 Press ON SCREEN twice.

The on-screen bar with pull-down menu appears on the TV.

Ex.: When playing a DVD



2 Press cursor ► / ◀ repeatedly to select (highlight) ◻ on the pull-down menu.



3 Press ENTER.

The pop-up window appears under the pull-down menu.



4 Use the number buttons (0 – 9) to enter the time.

You can specify the time in hours/minutes/seconds for DVD, and in minutes/seconds for VCD/CD.

Ex.: To play back from a point of 1 (hours): 02 (minutes): 49 (seconds) from the beginning for DVD.

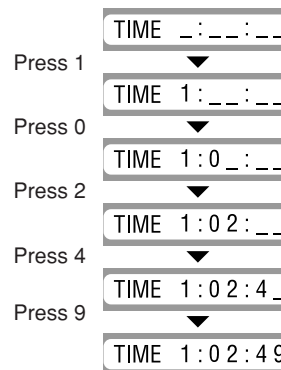

Ex.: To play back from a point of 62 (minutes): 49 (seconds) from the beginning for CD or VCD.

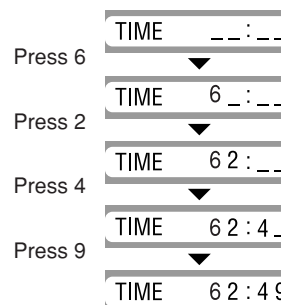

To correct a misentry

Pressing cursor ◀ erases the last entry.

Press cursor ◀ repeatedly until the wrong number is erased, then press the number buttons to enter the correct number(s) again.

5 Press ENTER.

The unit starts playback from the specified time.

To turn off the on-screen bar

Press ON SCREEN.

Advanced Disc Operations (continued)

■ Repeating Playback



You can repeat playback of the current title or chapter (for DVD), or track (for SVCD/VCD/CD).

- You can also repeat playback of a desired portion (A-B Repeat).

To repeat a current title, group, chapter, or all tracks

- For DVD/SVCD/VCD: **During playback**
- For CD: **During playback or while stopped**

1 Press ON SCREEN twice.

The on-screen bar with pull-down menu appears on the TV.
Ex.: When playing a DVD



2 Press cursor ► / ◀ repeatedly to select (highlight) on the pull-down menu.



3 Press ENTER.

The pop-up window appears under the pull-down menu.



4 Press cursor ▼ / ▲ repeatedly to select Repeat Play mode.

- Each time you press the button, Repeat Play mode changes as follows:

For DVD:

ALL → **A-B** → **TITLE** → **CHAPTER** → **OFF** → (back to the beginning)

For SVCD/VCD/CD:

ALL → **A-B** → **DISC** → **TRACK** → **OFF** → (back to the beginning)

ALL	Repeats all the discs loaded on the disc trays or of the program (the REPEAT ALL indicator lights up on the display)
A-B	Repeats a desired portion (the REPEAT indicator lights up on the display) (see the right column)
TITLE	Repeats the current title (the REPEAT indicator lights up on the display)
DISC	Repeats all tracks on the current disc (the REPEAT 1DISC indicator lights up on the display)
CHAPTER	Repeats the current chapter (the REPEAT 1 indicator lights up on the display)
TRACK	Repeats the current track (the REPEAT 1 indicator lights up on the display)
OFF	Select to cancel Repeat Play mode.

5 Press ENTER.

The setting changes and the pop-up window goes off.



- If you select “ALL” during Random Play, the all tracks of the disc are played repeatedly in random order.
- “A-B” cannot be selected during Program and Random Play or while a disc is not playing.

To turn off the on-screen bar

Press ON SCREEN.

To cancel the repeat playback

Select “OFF” in step 4, then press ENTER.

You can directly change Repeat Play mode (except A-B) by pressing REPEAT on the remote control. See page 32.

To repeat a desired portion



You can repeat playback of a desired portion by specifying the beginning (point A) and the ending (point B).

- A-B Repeat cannot be used on some DVDs.

- During playback

1 Press ON SCREEN twice.

The on-screen bar with pull-down menu appears on the TV.
Ex.: When playing a DVD



2 Press cursor ► / ◀ repeatedly to select (highlight) on the pull-down menu.



3 Press ENTER.

The pop-up window appears under the pull-down menu.



4 Press cursor ▼ / ▲ repeatedly to select “A-B.”



5 Press ENTER at the beginning of the portion you want to repeat (point A).

“◀ A - ” appears in the pop-up window.



- The REPEAT indicator also lights up on the display.

6 Press ENTER at the end of the portion you want to repeat (point B).

A-B repeat playback starts. The selected part (between point A and B) is played repeatedly.

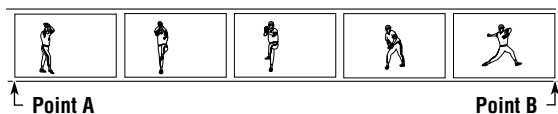

To turn off the on-screen bar

Press ON SCREEN.

To cancel the A-B repeat playback

Select "OFF" in step 4, then press ENTER.



While playing back a DVD

A-B Repeat is possible only within the same title.

Selecting a View Angle



While playing back a DVD containing multi-view angles, you can view the same scene from different angles.

The icon appears at the beginning of playback when the current scene has multi-view angles.

- You can also select the angle using the on-screen bar. See page 36 for details.

During playback

1 Press ANGLE.

The following pop-up window appears on the TV.

Ex.: The first view angle is selected out of 3 view angles recorded.

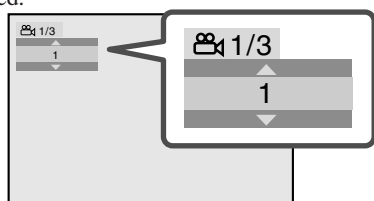

2 Press ANGLE repeatedly to select the desired view angle.

- Each time you press the button, the view angle changes.
Ex.: 1/3 ⇒ 2/3 ⇒ 3/3 ⇒ (back to the beginning)

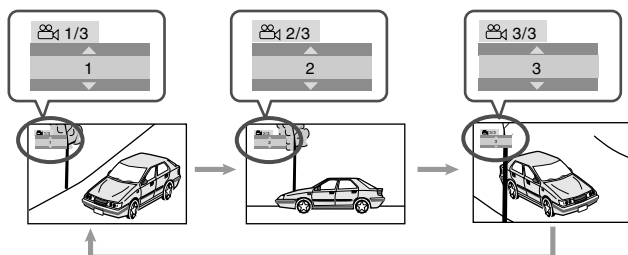

The pop-up window goes off if no operation is done for about 5 seconds.

Selecting the Subtitle Language



While playing back a DVD or SVCD containing subtitles in different languages, you can select the subtitle language to display on the TV.

The icon appears at the beginning of playback when the current scene has plural subtitles.

- Though you can do the following procedure for an SVCD which contains no subtitle, it is not effective.
- You can also select the subtitle language using the on-screen bar. See page 36 for details.

During playback

1 Press SUBTITLE.

The following pop-up window appears on the TV.

Ex.: "ENGLISH" is selected out of 3 subtitle languages recorded when playing back a DVD.

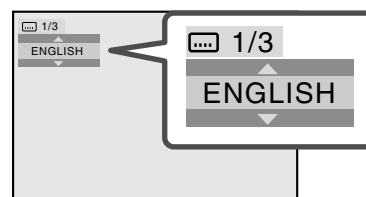

- For DVD:** Some subtitle languages may be abbreviated in the pop-up window. See "Language Code List" on page 68.

2 Press cursor ▼ / ▲ repeatedly to select the desired subtitle language.

- Each time you press the button, the subtitle language changes.

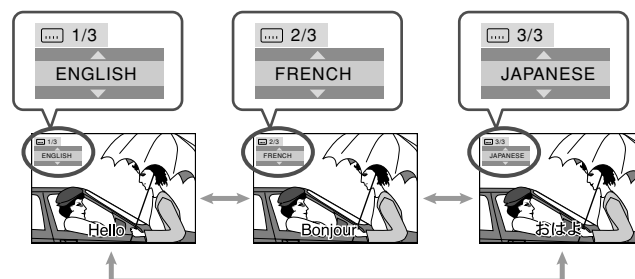

- For SVCD:** Pressing SUBTITLE repeatedly also changes the subtitles.

The pop-up window goes off if no operation is done for about 5 seconds.

To turn off the subtitle

- For DVD:** Press SUBTITLE to select "OFF" while the pop-up window appears on the TV.
- For SVCD:** Press SUBTITLE repeatedly until "OFF" appears on the pop-up window.

Advanced Disc Operations (continued)

Selecting the Audio Language



When a DVD contains audio languages (sound track), you can select the language (sound track) to listen to.

The icon appears at the beginning of playback when the current scene has plural audio languages.

- You can also select the audio language using the on-screen bar. See page 36 for details.

□ During playback

1 Press AUDIO.

The following pop-up window appears on the TV.

Ex.: "ENGLISH" is selected out of 3 audio languages recorded.

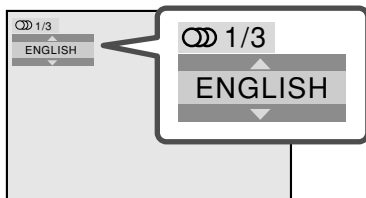

2 Press AUDIO repeatedly to select the desired audio language.

- Each time you press the button, the audio language changes.

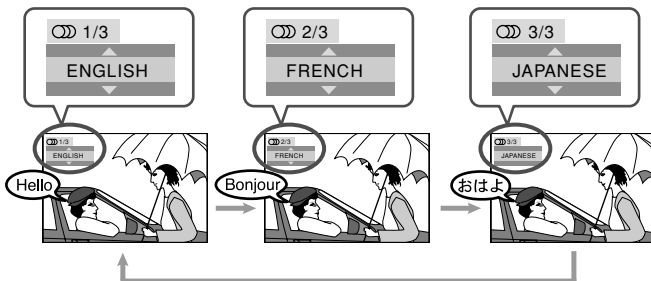

The pop-up window goes off if no operation is done for about 5 seconds.

Selecting the Audio Channel



When playing back some Karaoke SVCDs or VCDs, you can enjoy Karaoke by selecting the audio channel to play.

- You can also select the audio channel using the on-screen bar. See page 36 for details.

□ During playback

1 Press AUDIO.

The following pop-up window appears on the TV.

Ex.: "ST" (stereo) is selected when playing a VCD.

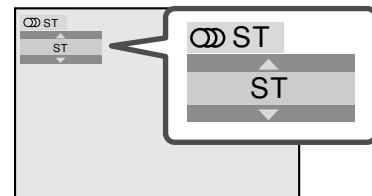

2 Press AUDIO repeatedly to select the desired audio channel.

- Each time you press the button, the audio channel changes.

For SVCD:

Ex.: **ST 1** ⇒ **ST 2** ⇒ **L 1** ⇒ **R 1** ⇒ **L 2** ⇒ **R 2** ⇒
(back to the beginning)

ST 1/ST 2	To listen to normal stereo (2-channel) playback of ST 1 or ST 2 channels.
------------------	---

L 1/L 2	To listen to the L (left) 1 or L 2 audio channel of either ST 1 or ST 2.
----------------	--

R 1/R 2	To listen to the R (right) 1 or R 2 audio channel of either ST 1 or ST 2.
----------------	---

For VCD:

Ex.: **ST** ⇒ **L** ⇒ **R** ⇒ (back to the beginning)

ST	To listen to normal stereo (2-channel) playback.
-----------	--

L	To listen to the L (left) audio channel.
----------	--

R	To listen to the R (right) audio channel.
----------	---

The pop-up window goes off if no operation is done for about 5 seconds.

Special Picture Playback



This unit provides special picture playback functions including still picture, frame-by-frame, slow-motion, and zoom.

■ Still picture and frame-by-frame playback

□ During playback

1 Press **II** once.

Still picture appears—Still picture playback.

2 Press **II** repeatedly.

- Each time you press the button, the still picture advances frame by frame—Frame-by-frame playback.

To return to normal playback

Press DISC ►.

■ Playing back in slow motion—Slow-motion playback

□ During playback

1 Press **II** at the point where you want to start playback in slow motion.

Still picture appears.

2 Press **SLOW+** (▶▶) or **SLOW-** (◀◀).

To play back in forward slow-motion, press **SLOW+** (▶▶).

To play back in reverse slow-motion (for DVD only), press **SLOW-** (◀◀).

- Each time you press the button, the playback speed changes as follows:

Forward:

▶▶ 1/32 ⇒ ▶▶ 1/16 ⇒ ▶▶ 1/8 ⇒ ▶▶ 1/4 ⇒
▶▶ 1/2

Reverse (for DVD only):

◀◀ 1/32 ⇒ ◀◀ 1/16 ⇒ ◀◀ 1/8 ⇒ ◀◀ 1/4 ⇒
◀◀ 1/2

To pause slow-motion playback

Press **II**.

To return to normal playback

Press DISC ►.



During slow-motion playback

No sound will be reproduced.

■ Zooming in

□ During playback or while paused

Press **ZOOM**.

- Each time you press the button, the magnification changes as follows:

For DVD:

x 1 (normal size) ⇒ x 1.8 ⇒ x 3 ⇒ (back to the beginning)

For SVCD/VCD:

x 1 (normal size) ⇒ x 1.5 ⇒ (back to the beginning)

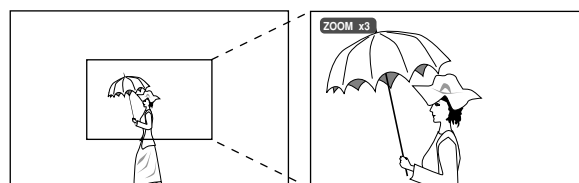

Ex.: When "ZOOM x3" is selected.

To move the zoomed-in position

Press cursor ▲/▼/▶/◀.

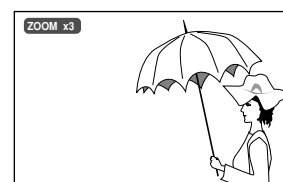

To return to normal playback

Press **ZOOM** repeatedly until "ZOOM x1" appears on the TV.



While zoomed in

The picture may look coarse.

Advanced Disc Operations (continued)

Changing the VFP Setting



The VFP (Video Fine Processor) function enables you to adjust the picture based on the picture tone, or personal preference.

- There is a time limit in doing the following steps. If the setting is canceled before you finish, start from step **1** again.

□ During playback

1 Press VFP.

The current VFP setting screen appears on the TV.

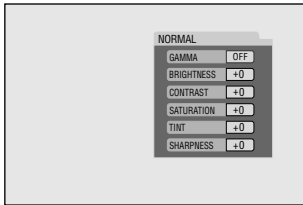

Ex.: When "NORMAL" is selected.

2 Press cursor ► / ◀ repeatedly to select the VFP mode.

- Each time you press the button, the VFP mode changes as follows.

NORMAL ⇄ **CINEMA** ⇄ **USER1** ⇄ **USER2** ⇄
(back to the beginning)

NORMAL	Normally select this.
CINEMA	Suitable for a movie source.
USER1/USER2	You can adjust parameters that affect the appearance of picture and can store the settings (see below).

To turn off the VFP setting screen

Press VFP.



If no operations are done for about 10 seconds

The VFP setting screen disappears.

To adjust the appearance of the picture

You can adjust the appearance of picture and store in "USER1" and "USER2."

□ During playback

1 Press VFP, then press cursor ► / ◀ repeatedly to select "USER1" or "USER2."

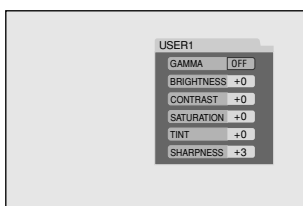

Ex.: When "USER1" is selected.

2 Press cursor ▼ / ▲ repeatedly to select a parameter you want to adjust.

Adjust the parameters so that the picture you are viewing appears as you prefer.

GAMMA	Adjust if the neutral color is bright or dark. The brightness of dark and bright portions is maintained. Available range: OFF, 1 (darkest) to 3 (brightest)
BRIGHTNESS	Adjust if the picture is bright or dark as a whole. Available range: -8 (darkest) to +8 (brightest)
CONTRAST	Adjust if the far and near position is unnatural. Available range: -7 to +7
SATURATION	Adjust if the picture is whitish or blackish. Available range: -7 (most blackish) to +7 (whitest)
TINT	Adjust if the human skin color is unnatural. Available range: -7 to +7
SHARPNESS	Adjust if the picture is indistinct. Available range: -8 to +8

3 Press ENTER.

VFP parameters list disappears, and the following pop-up window for the selected item appears on the TV.

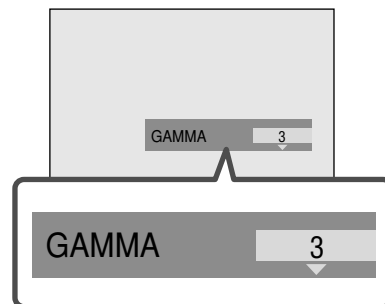

Ex.: When "GAMMA" is selected.

4 Press cursor ▼ / ▲ repeatedly to select the setting, then press ENTER.

Your adjustment is stored and the current VFP parameter list appears again.

5 Repeat steps 2 to 4 to adjust other parameters.

To turn off the VFP setting screen

Press VFP.

To activate your setting

Press VFP, then press cursor ► / ◀ repeatedly to select "USER1" or "USER2."



If no operations are done for about 10 seconds
The VFP setting screen disappears.

MP3/JPEG Disc Playback

This unit can play back MP3/JPEG files on a CD-R or CD-RW. We call a disc containing MP3 files “MP3 disc” and a disc containing JPEG files “JPEG disc” in this instruction.

- For details about other discs (DVD, SVCD, VCD, CD) playback, see pages 29 to 33.
- In this instruction, “file” is also referred to as “track.”
- Turn on your TV and select the correct input mode on the TV.

If “” appears on the TV when you press a button, the disc cannot accept an operation you have tried to do.

Notes for MP3/JPEG discs

- MP3/JPEG discs (either CD-R or CD-RW) require a longer readout time than normal discs. (It depends on the complexity of the folder/file configuration.)
- When making an MP3/JPEG disc, select ISO 9660 Level 1 or Level 2 as the disc format.
- This unit supports “multi-session” discs (up to 5 sessions).
- This unit cannot play “packet write” discs.
- Some MP3/JPEG discs may not be played back because of their disc characteristics or recording conditions.
- If both MP3 files and JPEG files are recorded on a disc, change the MP3/JPEG setting in the PICTURE menu to play the desired files (see page 61).

Notes for MP3 files

- This unit can play MP3 files only with the following file extensions: “.MP3”, “.Mp3”, “.mp3” and “.mp3”.
- ID3* tags cannot be shown on the display.
 - * An MP3 file can contain file information called an “ID3 Tag” where its album name, performer, track title, etc. are recorded.
- It is recommended that you make each MP3 file at a sampling rate of 44.1 kHz and at bit rate of 128 kbps. The unit cannot play back files made at bit rate of less than 64 kbps.

Notes for JPEG files

- The unit can play JPEG files only with the following file extensions: “.jpg”, “.jpeg”, “.JPG”, “.JPEG” and any uppercase and lowercase combinations (such as “.Jpg”).
- It is recommended that you record a file at 640 x 480 resolution. (If a file has been recorded at a resolution of more than 640 x 480, it will take a longer time to be shown.)
- This system can play only baseline JPEG files*. Progressive JPEG files* or lossless JPEG files* cannot be played.
 - * – Baseline JPEG format: Used for digital cameras, web, etc.
 - Progressive JPEG format: Used for web.
 - Lossless JPEG format: An old type and rarely used now.
- This unit may not play back properly JPEG files which are recorded by the devices other than digital still camera.



Some tracks on an MP3/JPEG disc are skipped and may not be played back normally

This is not malfunction. It may result from their recording processes and conditions.

The following functions are not available for MP3/JPEG disc playback:

- Fast-forward/reverse search
- On-screen bar



About Program Play and Random Play

You cannot use Program Play and Random Play for JPEG disc, but for MP3 disc.

Basic MP3/JPEG Disc Operations

To start playback

Load an MP3/JPEG disc, then select the disc.

On the remote control:

Press the corresponding disc number button (DISC1 – DISC5) while holding down SHIFT.

On the front panel:

Press the corresponding disc number button (DISC1 – DISC5).

Playback starts (see page 28).

- When loading a MP3 disc, the MP3 CONTROL screen appears on the TV.
- When loading a JPEG disc, Slide-show playback starts. Each file (still picture) is shown on the TV for about 3 seconds, then changed to the next file, one after another.
- When all files in a group have been played, the unit plays files in the next group.

To stop playback temporarily

Press .

To start playback again, press DISC .

To select a file directly

On the remote control ONLY:

Press the number buttons (1 – 10, +10) to enter the file number. Playback begins from the selected file.

- Ex.:
- To select the file number 3, press 3.
 - To select the file number 14, press +10 then 4.
 - To select the file number 24, press +10, +10, then 4.
 - To select the file number 110, press +10 ten times, then 10.

To select groups

Press GROUP SKIP  /  repeatedly while holding down SHIFT as many times as required.

To skip forward or backward to other files

Press  /  repeatedly as many times as required.

- To skip back to the beginning of the current file, press  once.

To stop playback completely

Press .

For JPEG discs: JPEG CONTROL screen appears on the TV.

Advanced Disc Operations (continued)

Operations through the MP3/JPEG CONTROL Screens

You can search for and play the desired files in a group through the MP3/JPEG CONTROL screens shown on TV.

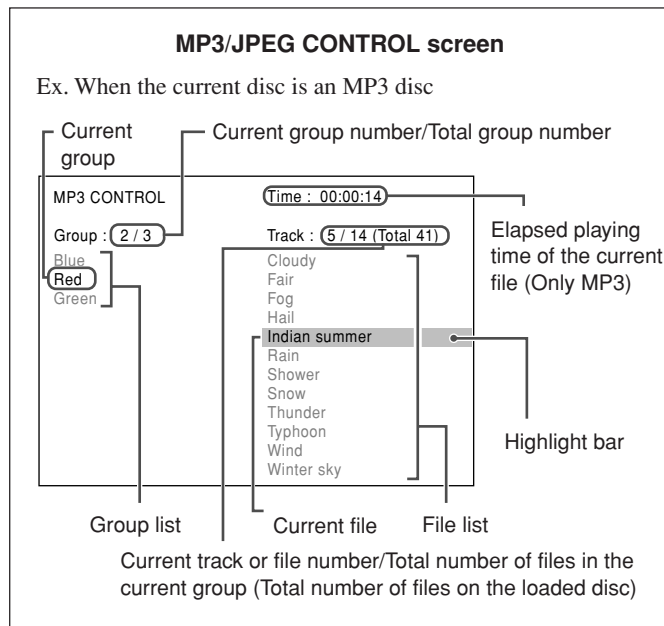

About the MP3/JPEG CONTROL screens

- Some group and file names may not be displayed correctly because of their recording conditions.
- The order of groups and files on an MP3/JPEG disc may be displayed differently from the order displayed on your personal computer.
- Up to 12 groups and files are displayed on the TV at a time. Pressing cursor **▲/▼/▶/◀** repeatedly shows the succeeding groups and files one by one.

Basic MP3/JPEG CONTROL Operations

- 1 Press cursor **◀** to move the highlight bar to the group list.
- 2 Press cursor **▼ / ▲** repeatedly to select a group.
 - When you select a group, the file list of the selected group is shown on the right.
- 3 Press cursor **▶** to move the highlight bar to the right file list.
- 4 Press cursor **▼ / ▲** repeatedly to select a file.

5 For MP3:

Press **DISC ▶** (or **ENTER**).

Playback starts from the selected file.

For JPEG:

Press **DISC ▶**.

Slide-show starts from the selected file.

- Press **ENTER** to show the selected file as a still picture.
- While a JPEG file is played back, the JPEG CONTROL screen disappears.

To stop playback, press **■**.

For JPEG discs: JPEG CONTROL screen appears on the TV.



If a black screen continuously appears in Slide-show

The file currently played may be non-baseline JPEG file. In this case, select a playable file (a baseline JPEG file) again (e.g., pressing **■** or **MENU** to show the JPEG CONTROL screen, etc.). Note that it may take a long time to select another file.

Repeating Playback—Repeat Play

You can repeat playback.

On the remote control ONLY:

Press **REPEAT** during or before play.

- Each time you press the button, Repeat Play mode changes as follows:

For MP3:

REPEAT TRACK ⇔ **REPEAT GROUP** ⇔ **REPEAT DISC** ⇔ **REPEAT ALL** ⇔ canceled ⇔ (back to the beginning)

For JPEG:

REPEAT GROUP ⇔ **REPEAT DISC** ⇔ **REPEAT ALL** ⇔ canceled ⇔ (back to the beginning)

REPEAT TRACK	Repeats the current track (the REPEAT 1 indicator lights up on the display)
REPEAT GROUP	Repeats the current group (the REPEAT indicator lights up on the display)
REPEAT DISC	Repeats all tracks on the current disc (the REPEAT 1DISC indicator lights up on the display)
REPEAT ALL	Repeats all the discs loaded on the disc trays or all steps of the program (the REPEAT ALL indicator lights up on the display)

To stop playing, press **■**.

To cancel Repeat Play, press **REPEAT** repeatedly until Repeat Play mode indicators go off from the display.

- Turning off the unit will also cancel Repeat Play.

Recording

The buttons emphasized in the illustration below are used and explained in the following section (pages 47 and 48).

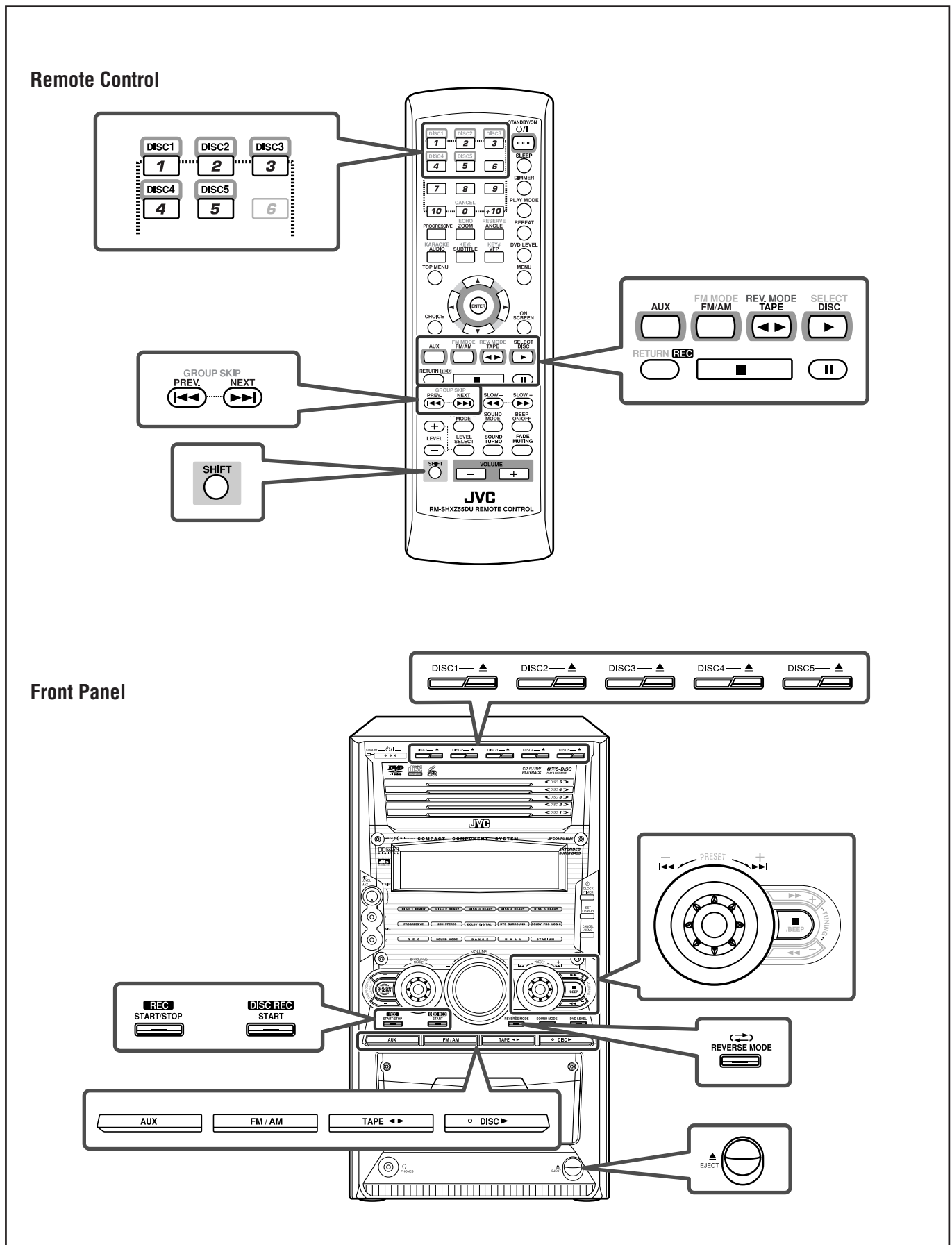

Recording (continued)

IMPORTANT:

- It may be unlawful to record or play back copyrighted material without the consent of the copyright owner.
- The recording level is automatically set correctly. Thus, during recording you can adjust the sound you are actually listening to without affecting the recording level.
- If there are excessive noise or static in the recording you have made, the unit may be too close to a TV. Increase the distance between the TV and the unit.
- You can only use type I tape for recording.

To protect your recording

Cassettes have two small tabs on the back to protect from unexpected erasure or re-recording. To protect your recording, remove these tabs.

To re-record on a protected tape, cover the holes with adhesive tape.

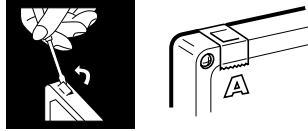

Recording on a Tape

- 1 Press **EJECT** and insert a recordable cassette with the exposed part of the tape down.

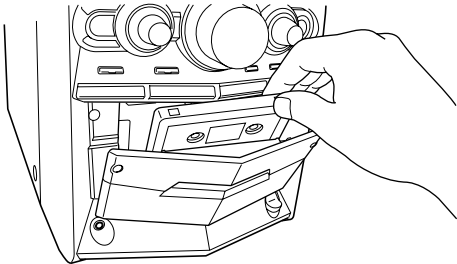

- 2 Close the cassette holder gently.

- If you want to record on both sides of a tape, see “To record on both sides—Reverse mode.”

- 3 Check the tape direction of the cassette deck.

- If the tape direction is not correct, press **TAPE** **◀▶** twice then press **■** to change the tape direction.

- 4 Start playing the source—FM, AM, disc player, or auxiliary equipment connected to the **AUX IN** jacks.

- When the source is the disc player, you can also use Synchronized Recording (see page 48).

- 5 Start recording.

On the remote control:

Press and hold **REC** while holding down **SHIFT** for more than 1 second.

On the front panel:

Press **REC START/STOP**.

The REC (recording) lamp start flashing when recording starts, and the tape direction indicator (▶ or ◀) starts flashing slowly.

- If no cassette is inserted, “NO TAPE” appears on the display. If a protected tape has been inserted, “NO REC” appears on the display.

To stop recording immediately, press **■** (or **REC START/STOP** or **■** on the front panel).

To remove the cassette, press **EJECT** to open the cassette holder.

To record on both sides—Reverse mode

On the remote control:

Press **REV. MODE** while holding down **SHIFT**.

On the front panel:

Press **↔** **REVERSE MODE**.

The Reverse mode indicator lights up on the display like—(**↔**).

- When using the Reverse mode for recording, start recording in the forward (▶) direction first. Otherwise, recording will stop when only one side (reverse) of the tape is recorded.

To cancel the Reverse mode, press the button again so that the Reverse mode indicator lights up on the display like—**↔**.

Synchronized Recording

By using Synchronized Recording, you can start and stop both disc play and tape recording at the same time.

Everything on the disc goes onto the tape in the order it is on the disc, or according to the order you have made for Program Play.

- You cannot use Synchronized Recording with Repeat Play (Repeat Play will be canceled).

1 Press EJECT and insert a recordable cassette with the exposed part of the tape down.

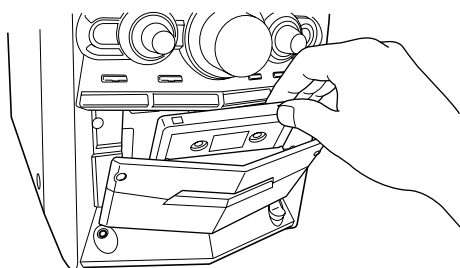

2 Load a disc.







3 Select a disc.

For recording a whole disc (except JPEG discs):

Press the corresponding disc number button (DISC1 – DISC5) where a disc is loaded in step 2, then press .

For recording from a desired track on a disc:

You can select a track to start recording with.

- (1) Press the corresponding disc number button (DISC1 – DISC5) while holding down SHIFT for which you have loaded a disc in step 2, then press .
- (2) **Only for MP3 discs:** Press GROUP SKIP ( or ) while holding down SHIFT to select a group.
- (3) Press  /  (or turn  /  control on the front panel) to select a track.

For recording with Program Play:

You can program tracks to record from plural discs with your preferred order.

- (1) Load all discs you want to program from.
- (2) Complete the procedure for Program Play (see page 33 for details) without starting playback.

4 Press DISC REC START.

The disc player starts playing when the cassette deck starts recording.



“DISC REC” appears on the display and the REC (recording) lamp flashes when recording starts.

- The unit creates a 4-second blank portion on the recording tape. (Remember a 4-second blank is important when using Music Scan. See page 24.)
- When the recording is done, “DISC REC FINISHED” scrolls on the display, and the REC (recording) lamp stops flashing. Both the cassette deck and the disc player stop automatically.

To stop recording, press  (or REC START/STOP or  on the front panel).





To record without creating a 4-second blank

Synchronized Recording creates 4-second blank portion on the recording tape between each song. To record without creating a 4-second blank portion, follow the steps below after you have completed the step 1 to 3 on the left column.

- 1 Press DISC .
- 2 Press  on the remote control to pause playback.
- 3 Press  to go back to the beginning of the track.
 - “0:00” flashes on the display.
- 4 Press DISC REC START on the front panel to start recording.



While synchronized recording...

- You cannot use  / ,  / , DVD LEVEL and source buttons (including DISC ).
- You can adjust sound setting (Subwoofer level, Sound Turbo, Sound mode), but the settings do not affect the recording sound.
- While recording DVD multi-channel software, the sound will be mixed down to 2-channel signals (stereo).

To record on both sides—Reverse mode



On the remote control:

Press REV. MODE while holding down SHIFT.

On the front panel:

Press  REVERSE MODE.

The Reverse mode indicator lights up on the display like—.

- When using the Reverse mode for Synchronized Recording, start recording in the forward () direction first. When the tape reaches its end while recording a song in the forward direction () , the last song will be re-recorded at the beginning of the reverse side ().

If you start recording on the reverse side () first, recording will stop when only one (reverse) side of the tape is recorded.

To cancel Reverse mode, press the button again so that the Reverse mode indicator lights up on the display like—.



When using Sleep Timer while Synchronized Recording is in use

Set enough time to allow for the disc to finish playing; otherwise, the power will go off before recording is completed.

Enjoying Karaoke

The buttons emphasized in the illustration below are used and explained in the following section (pages 50 to 52).

Remote Control

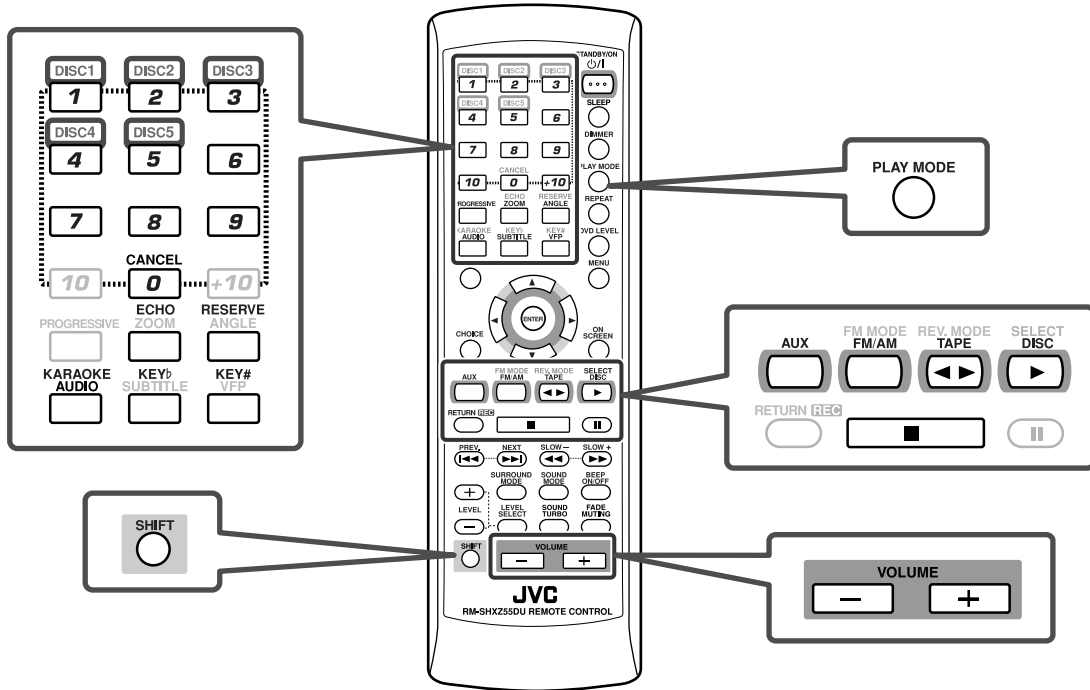

Front Panel

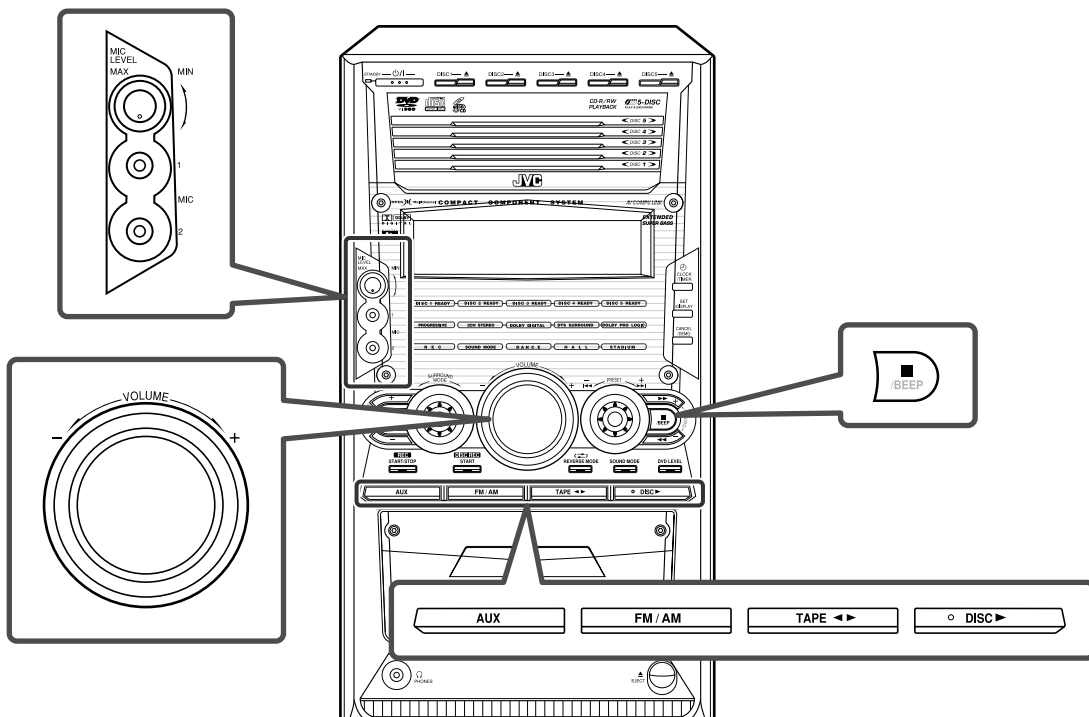

Singing Along (Karaoke)

You can enjoy singing along (Karaoke) and microphone mixing by using two microphones.

- MIC LEVEL adjustment is valid for both microphones connected to the MIC 1 and MIC 2 jacks.

IMPORTANT:

- Always set MIC LEVEL to MIN when connecting or disconnecting the microphone.
- Cancel the Karaoke mode (select “MIC OFF”) by pressing KARAOKE while holding down SHIFT after you finish enjoying Karaoke.
- Karaoke is also canceled when you turn off the power or when you change the playback source.



DO NOT keep microphones connected while they are not in use.

Vocal Masking

The Vocal Masking reduces the lead vocal of any 2-channel playing source, and allows you to replace it by singing into the microphones as the music plays.

- While playing a DVD multi-channel discs, it will be mixed down and played back as a 2-channel source.

- 1 Turn MIC LEVEL to MIN.
- 2 Connect the microphone(s) (not supplied) by plugging it into the MIC 1 and/or MIC 2 jack.
- 3 Start playing the source—FM, AM, disc player, or auxiliary equipment connected to the AUX IN jacks.
- 4 Press KARAOKE repeatedly while holding down SHIFT until “KARAOKE” appears on the display.

- Each time you press the buttons, the Karaoke mode changes as follows.

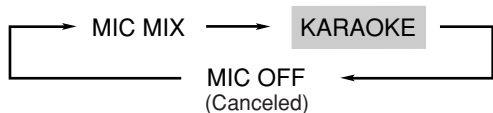

The KARAOKE indicator also lights up on the display.

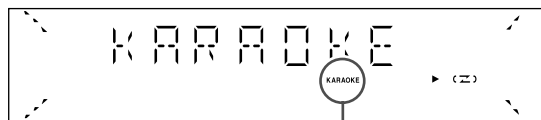

KARAOKE indicator

- 5 Turn MIC LEVEL and VOLUME as you sing into the microphone(s).

- By pressing REC START/STOP, you can record your singing along if you want. (See page 47.)

To cancel from the Karaoke mode, change the source to play.

- Turning off the unit also cancels the Karaoke mode.

To exit from the Karaoke mode, press KARAOKE while holding down SHIFT repeatedly until “MIC OFF” appears on the display.

To apply an echo to your voice

You can apply echo effect to your voice.

On the remote control ONLY:

Press ECHO while holding down SHIFT.

The ECHO indicator also lights up on the display.

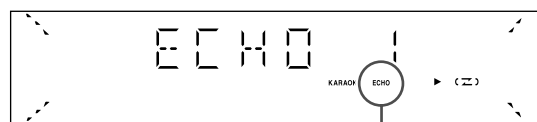

ECHO indicator

- Each time you press the buttons, the echo level changes as follows.

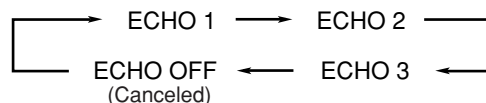

As the number increases, a stronger echo effect applies to your voice.

To cancel echo, press ECHO repeatedly while holding down SHIFT until “ECHO OFF” appears on the display.

- Turning off the unit also cancels the echo effect.

To adjust the Key

You can adjust the key to fit to your tone.

- This function is available while playing back a disc, not for the other sources like FM or AM.

On the remote control ONLY:

Press KEY # or KEY b while holding down SHIFT to adjust the key during playback.

The following indication appears on the display. Adjustable key range is “-6” to “+6.”



- To raise the key, press KEY #.
- To lower the key, press KEY b.

You can also check your key adjustment on the TV screen.

To cancel the key control, set the key to “KEYCON 0” by pressing KEY # or KEY b while holding down SHIFT when you finish your singing along.

- The key will be automatically reset to “KEYCON 0” after the current track or title is over.



If you use the following sources as the playing source for Karaoke, you cannot get the satisfactory results

- Radio programs—a radio signal is not as reliable as the signals coming from a tape or disc.
- Monaural sources.
- Poorly dubbed tapes.
- Sources recorded with duets, strong echo, a chorus, or only a few instruments.

Enjoying Karaoke (continued)

Microphone Mixing

When the playback source is a multi-channel software, it will be played back as a 2-channel source.

- For DVD/SVCD/VCD/CD:
 - During playback or while stopped
- For MP3:
 - During playback

- 1** Connect the microphone(s).
- 2** Start playing the source—FM, AM, disc player, or auxiliary equipment connected to the AUX IN jacks.
- 3** Press **KARAOKE** repeatedly while holding down **SHIFT** until “MIC MIX” appears on the display.
 - Each time you press the buttons, the Karaoke mode changes as follows.

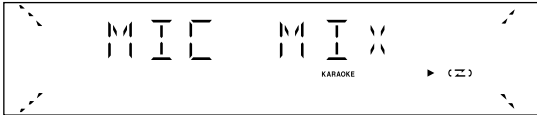

- 4** Turn **MIC LEVEL** and **VOLUME** as you sing into the microphone(s).
 - By pressing **REC START/STOP**, you can record your singing along if you want. (See page 47.)
 - By pressing **ECHO** while holding down **SHIFT**, you can apply echo effect to your voice. (See page 50.)
 - While playing back a disc, you can adjust the key to fit to your tone.



If the playing disc is a multiplex Karaoke disc

You can enjoy multiplex sound by pressing **AUDIO** (see page 41).

■ To use microphone only

Without any background sound, you can use your microphone(s), and record it if you want.

- 1** Connect the microphone(s).
- 2** Press the disc number button of which a disc is loaded while holding down **SHIFT** (or press the disc number on the front panel), then ■.
- 3** Press **KARAOKE** repeatedly while holding down **SHIFT** until “MIC MIX” appears on the display.
 - If no disc is loaded on the selected disc tray in step 2, **KARAOKE** button does not work.
 - By pressing **ECHO** while holding down **SHIFT**, you can apply echo effect to your voice. (See page 50.)
 - Each time you press the buttons, the Karaoke mode changes as follows.



- 4** Turn **MIC LEVEL** and **VOLUME** as you speak into the microphone(s).
 - By pressing **REC START/STOP**, you can record your singing along if you want. (See page 47.)



If howling or squealing (feedback) occurs while using the microphone(s)

Take the following actions to prevent these noises.

- Adjust **MIC LEVEL** and **VOLUME**.
- Avoid pointing the microphone(s) towards the speakers.
- When two microphones are connected, turn off the unused microphone.

Reserving Karaoke Songs—Karaoke Program Play

You can determine the playback order of the titles or tracks on the disc player. You can program up to 12 steps.

On the remote control ONLY:

- 1 Load discs.
- 2 Press DISC ►, then ■.
- 3 Press RESERVE while holding down SHIFT.

The Karaoke reserve screen appears on the TV.

No	Disc	Gr/Tt	Tr/Chap
1			
2			
3			
4			
5			

- The PROGRAM indicator starts flashing on the display.

- 4 Press one of the number buttons to select a disc tray you want to program.

The selected disc number is shown on the TV screen.

- 5 Press the number buttons to select a song.

The selected song number is shown on the TV screen.

No	Disc	Gr/Tt	Tr/Chap
8	2	3	4
9	3	3	5
10		2	8
11			
12			

① Step number
 ② Selected disc tray number
 ③ Selected group/title number
 ④ Selected track/chapter number
 ⑤ Cursor

Ex.: To select number 5, press 5.
 To select number 10, press 10.
 To select number 20, press +10, then 10.
 To select number 23, press +10, +10, then 3.

- When you program a track from a SVCD, VCD or CD, you can skip the group/title number by pressing ENTER.
- You can erase the last programmed step by pressing CANCEL while holding down SHIFT.

- 6 Repeat steps 4 and 5 to program other songs you want.

- Each time you press CANCEL while holding down SHIFT, the last programmed step is erased from the program.

- 7 Press KARAOKE repeatedly while holding down SHIFT until “MIC MIX” appears on the display.

- Each time you press the buttons, the Karaoke mode changes as follows.



The KARAOKE indicator lights up on the display.

For multiplex Karaoke disc: Press AUDIO to select a channel when you start playing a disc.

- Refer to the instruction supplied to the disc for details.

- 8 Press DISC ►.

The titles and tracks are played in the order you have programmed.

- The number of the title or track currently played back is deleted from the Karaoke reserve screen.
 Playback stops after playing back all reserved step.

To check and modify the reserved songs

You can check and modify the program during play back.

On the remote control ONLY:

Press RESERVE while holding down SHIFT.

The Karaoke reserve screen appears on the TV.

To erase a reserved step, press cursor ▼ / ▲ repeatedly to highlight the desired step number, then press CANCEL while holding down SHIFT.

To add steps before or after playing, press cursor ▼ / ▲ repeatedly to move the cursor to the step number you like to add the song to, then select a song by following steps 4 and 5.

To erase the entire program, press ■ before or after playback.

To erase the Karaoke reserve screen, press RESERVE while holding down SHIFT.

To stop Karaoke Program Play

Press ■.

Karaoke reserve screen appears on the TV.

To exit from the Karaoke mode, press KARAOKE while holding down SHIFT repeatedly until “MIC OFF” appears on the display.

To exit from Karaoke Program Play

On the remote control ONLY:

Press RESERVE while holding down SHIFT before or after playback.

Karaoke reserve screen goes off from the TV, and the PROGRAM indicator also goes off from the display.

- Contents you have reserved is memorized.

Using the Timers

The buttons emphasized in the illustration below are used and explained in the following section (pages 54 to 57).

Remote Control

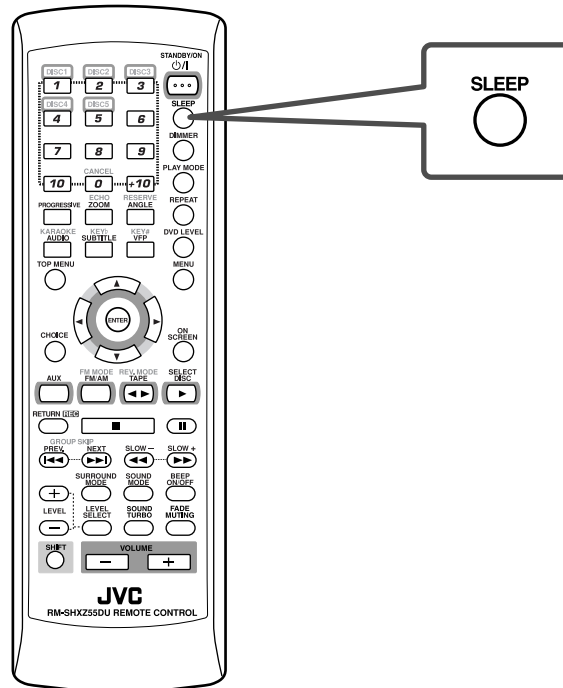

Front Panel

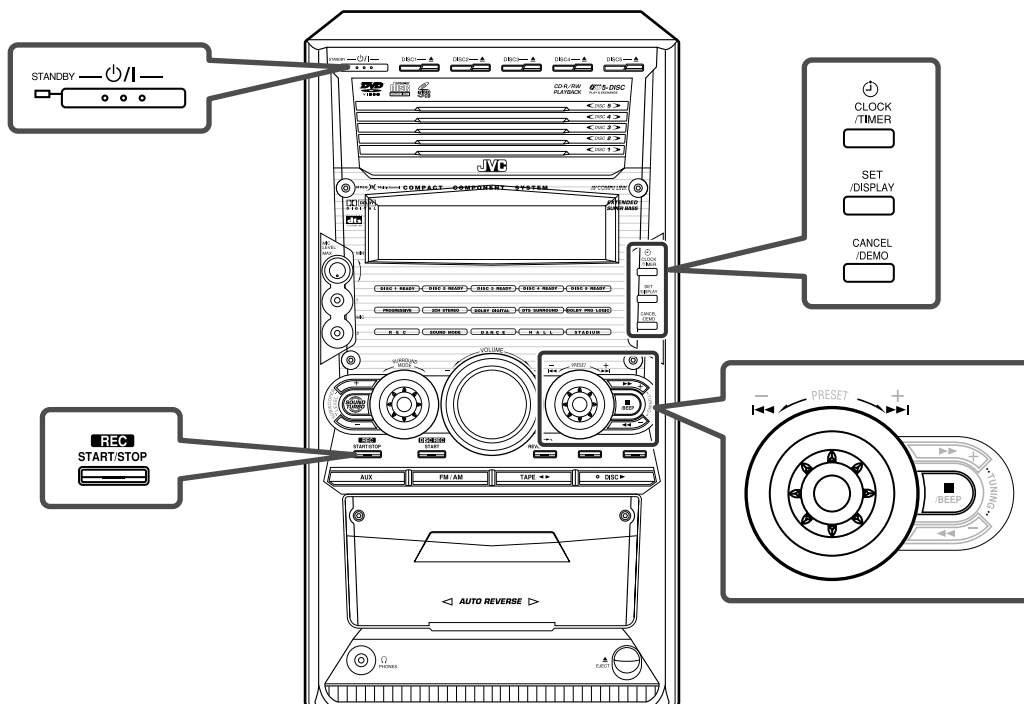

There are three timers available—DAILY (Daily Timer), REC (Recording Timer), and SLEEP (Sleep Timer).

- Before using the timers, set the clock built in the unit. (See page 13.)

Using Daily Timer

With Daily Timer, you can wake up to your favorite music or radio program.

- You can set the timers whether the unit is on or off.

How Daily Timer actually works

The unit automatically turns on, sets the volume level to the preset level, and starts playing the specified source when the on-time comes. (“DAILY” and the DAILY indicator on the display flash just before the on-time. The DAILY indicator continues flashing while the timer is operating.) Then, when the off-time comes (“DAILY OFF” appears on the display just before the off-time), the unit automatically turns off (standby).

The Daily Timer works everyday automatically. If you do not want to use the Daily Timer, turn it off. (See “To turn on or off Daily Timer” on page 55.) The timer setting remains in memory until you change it.

- There is a time limit in doing the following steps. If the setting is canceled before you finish, start from step 1 again.
- To correct a misentry while setting the timer, press CANCEL/ DEMO.

Before you start...

- When using a disc as the source to play:
 - Make sure there is a disc on the selected disc tray.
 - The Daily Timer cannot be able to use with JPEG discs.
- When using a tape as the source to play:
 - Make sure that a tape is in the cassette deck.
 - Make sure that the tape direction is correct.
- When using an external component as the source to play:
 - Set the timer equipped on the external component to the same time.

On the front panel ONLY:

1 Press \odot CLOCK/TIMER repeatedly until “DAILY” appears on the display.

The \odot (Timer) indicator lights up and the DAILY (Daily Timer) indicator starts flashing.



- Each time you press the button, the timer setting modes change as follows:

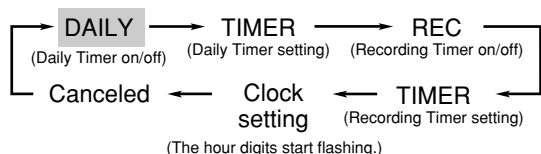

2 Press \odot CLOCK/TIMER again.

“TIMER” appears for about 2 seconds, then the unit enters on-time setting mode.



3 Set the on-time you want the unit to turn on at.

- (1) Turn $\blacktriangleright\blacktriangleright$ / $\blacktriangleleft\blacktriangleleft$ to set the hour, then press SET/DISPLAY.
- (2) Turn $\blacktriangleright\blacktriangleright$ / $\blacktriangleleft\blacktriangleleft$ to set the minute, then press SET/DISPLAY. “SET” appears for about 1 second, then the unit enters off-time setting mode.



4 Set the off-time you want the unit to turn off (standby) at.

- (1) Turn $\blacktriangleright\blacktriangleright$ / $\blacktriangleleft\blacktriangleleft$ to set the hour, then press SET/DISPLAY.
- (2) Turn $\blacktriangleright\blacktriangleright$ / $\blacktriangleleft\blacktriangleleft$ to set the minute, then press SET/DISPLAY. “SET” appears for about 1 second, then the unit enters source selecting mode.



5 Turn $\blacktriangleright\blacktriangleright$ / $\blacktriangleleft\blacktriangleleft$ to select the source to play, then press SET/DISPLAY.

“SET” appears for about 1 second.

- As you turn $\blacktriangleright\blacktriangleright$ / $\blacktriangleleft\blacktriangleleft$, the source changes as follows:



- DISC:** plays a disc from a track/chapter of a group/ title on specified disc.
→ Go to step 6.
- TAPE:** plays a tape in the cassette deck.
→ Go to step 7.
- AUX IN:** plays an external source.
→ Go to step 7.
- TUNER FM:** tunes in to a specified preset FM station.
→ Go to step 6.
- TUNER AM:** tunes in to a specified preset AM station.
→ Go to step 6.

Using the Timers (continued)

6 When selecting “TUNER FM” or “TUNER AM”:

Turn ►►/◄◄ to select a preset station number, then press SET/DISPLAY.

“SET” appears for about 1 second each time you select the number, then the unit enters volume setting mode.

When selecting “DISC”:

(1) Turn ►►/◄◄ to select the disc number, then press SET/DISPLAY.

“SET” appears for about 1 second.

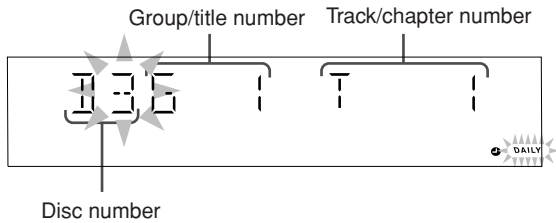

Ex.: Disc number 3 is selected.

(2) Repeat step (1) to select the group/title number, then select track/chapter number.

“SET” appears for about 1 second each time you select the number, then the unit enters volume setting mode.

- If you select a SVCD, VCD or CD, first press SET/DISPLAY to skip the group/title number entry, then enter the track number.
- If you select a DVD, you can select the title number and the chapter number. (However, for some DVDs, this does not work properly.)

7 Turn ►►/◄◄ to set the volume level.

• The volume level changes as follows:

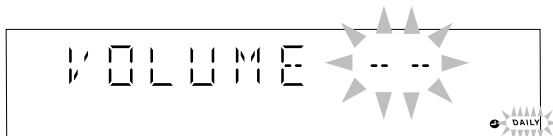
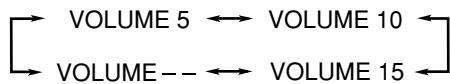

- If you select “VOLUME --,” the volume is set to the level when the unit has been turned off.

8 Press SET/DISPLAY to complete the Daily Timer setting.

The DAILY (Daily Timer) indicator stops flashing and remains lit. “OK ✓” appears on the display for about 2 seconds.

Then the settings you have done are shown in sequence for your confirmation.

9 Press ◻/I to turn off the unit (standby) if you have set the Daily Timer with the unit turned on.

- The unit will turn on about one minute before the on-time comes.



- **When you select a DVD as the source to play**
Playback may start a little earlier before the on-time comes.
- **If the unit is turned on before the on-time comes**
Daily Timer does not work.
- **If you unplug the AC power cord or if a power failure occurs**
Once you set the timer, the timer setting may remain stored in memory in a few days. Check whether the timer setting still remains.

To turn on or off Daily Timer

1 Press ◻ CLOCK/TIMER repeatedly until “DAILY” appears on the display.

The DAILY (Daily Timer) indicator starts flashing.

2 To turn off the Daily Timer, press CANCEL/DEMO.

The DAILY (Daily Timer) and the ◻ (Timer) indicators go off from the display (“DAILY OFF” appears for a while).

The Daily Timer is canceled, but the settings for the Daily Timer remain in memory.

DAILY OFF

To turn on the Daily Timer, press SET/DISPLAY.

“OK ✓” appears on the display for about 2 seconds.

Then the settings you have done are shown in sequence for your confirmation.

Using Recording Timer

With Recording Timer, you can make a tape of a radio broadcast automatically.

Before you set the recording timer, set the preset numbers for the radio stations (see page 22).

- You can set the timers whether the unit is on or off.

How Recording Timer actually works

The unit automatically turns on, tunes in to the specified station, sets the volume level to “MIN,” and starts recording when the on-time comes. (“REC” and the REC indicator on the display flash just before the on-time. The REC indicator continues flashing while the timer is operating.) Then, when the off-time comes (“REC OFF” appears on the display just before the off-time), the unit automatically turns off (standby).

The timer setting remains in memory until you change it.

- There is a time limit in doing the following steps. If the setting is canceled before you finish, start from step 2 again.
- To correct a mistake while setting the timer, press CANCEL/DEMO.

On the front panel ONLY:

1 Insert a recordable cassette with the exposed part of the tape down.

2 Press  CLOCK/TIMER repeatedly until “REC” appears on the display.

The  (Timer) indicator lights up and the REC (Recording Timer) indicator starts flashing.

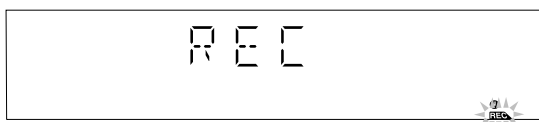

- Each time you press the button, the timer setting modes change as follows:

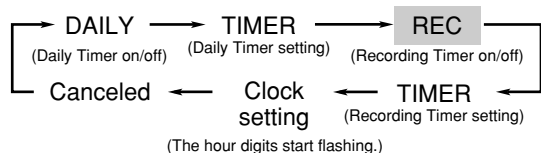





3 Press  CLOCK/TIMER again.

“TIMER” appears for about 2 seconds, then the unit enters on-time setting mode.







4 Set the on-time you want the unit to turn on at.

- Turn  /  to set the hour, then press SET/DISPLAY.
- Turn  /  to set the minute, then press SET/DISPLAY.

“SET” appears for about 1 second, then the unit enters off-time setting mode.







5 Set the off-time you want the unit to turn off (standby) at.

- Turn  /  to set the hour, then press SET/DISPLAY.
- Turn  /  to set the minute, then press SET/DISPLAY.

“SET” appears for about 1 second, then the unit enters preset station selection mode.

6 Select a preset station.

- Turn  /  to select the band (“TUNER FM” or “TUNER AM”), then press SET/DISPLAY. “SET” appears for about 1 second.
- Turn  /  to select a preset station number, then press SET/DISPLAY.

The REC (Recording Timer) indicator stops flashing and remains lit. “OK ✓” appears on the display for about 2 seconds.

Then the settings you have done are shown in sequence for your confirmation.

7 Press  to turn off the unit (standby) if necessary.

- The unit will turn on about one minute before the on-time comes.



- If you want to listen to another source while recording**
Press  (or REC START/STOP on the front panel) to stop recording. Without stopping it, you cannot change the source.
- If you unplug the AC power cord or if a power failure occurs**
Once you set the timer, the timer settings may remain stored in memory for a few days. Check whether or not the timer settings still remain.

Using the Timers (continued)

To turn on or off Recording Timer

- 1 Press **CLOCK/TIMER** repeatedly until “REC” appears on the display.

The REC (Recording Timer) indicator starts flashing.

- 2 To turn off the Recording Timer, press **CANCEL/DEMO**.

The REC (Recording Timer) and the **(Timer)** indicators go off from the display (“REC OFF” appears for a while).

The Recording Timer is canceled, but the settings for the Recording Timer remain in memory.

REC OFF

To turn on the Recording Timer, press **SET/DISPLAY**.

“OK ✓” appears on the display for about 2 seconds.

Then the settings you have done are shown in sequence for your confirmation.

Using Sleep Timer

With Sleep Timer, you can fall asleep to music. You can set Sleep Timer only while the unit is turned on.

How Sleep Timer actually works

The unit automatically shuts off after the specified time length passes.

On the remote control ONLY:

1 Press SLEEP.

The time length until the shut-off time appears.

The **(Timer)** indicator lights up and the SLEEP indicator starts flashing on the display.

- Each time you press the button, the time length changes as follows:

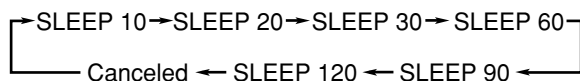

- If the built-in clock has not been set, “CLOCK ADJUST” appears on the display (see page 13).

2 Wait for about 5 seconds after specifying the time length.

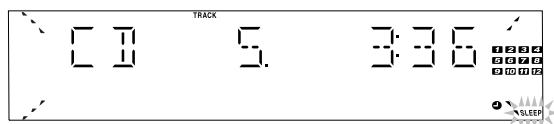

The SLEEP indicator flashes slowly until it shuts off the power.

To check the remaining time until the shut-off time, press SLEEP once so that the remaining time (minutes) until the shut-off time power appears for about 5 seconds.

To change the shut-off time, press SLEEP repeatedly until the desired time length appears on the display.

To cancel the setting, press SLEEP repeatedly so that the SLEEP indicator goes off.

- Sleep Timer is also canceled when you turn off the unit.

Timer Priority

Since each timer can be set separately, you may wonder what happens if the settings for these timers overlap.

Recording Timer has priority over Daily Timer and Sleep Timer. Below are some examples.

- If Sleep Timer is set to come on while Recording Timer is operating, Sleep Timer will be canceled when the Recording Timer starts.

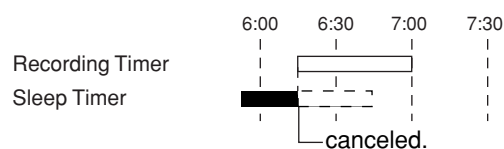

- If Recording Timer and Daily Timer are set to come on at the same time, Recording Timer will be activated.

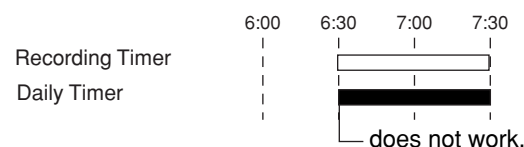

Choice Menu Operations

The buttons emphasized in the illustration below are used and explained in the following section (pages 59 to 66).

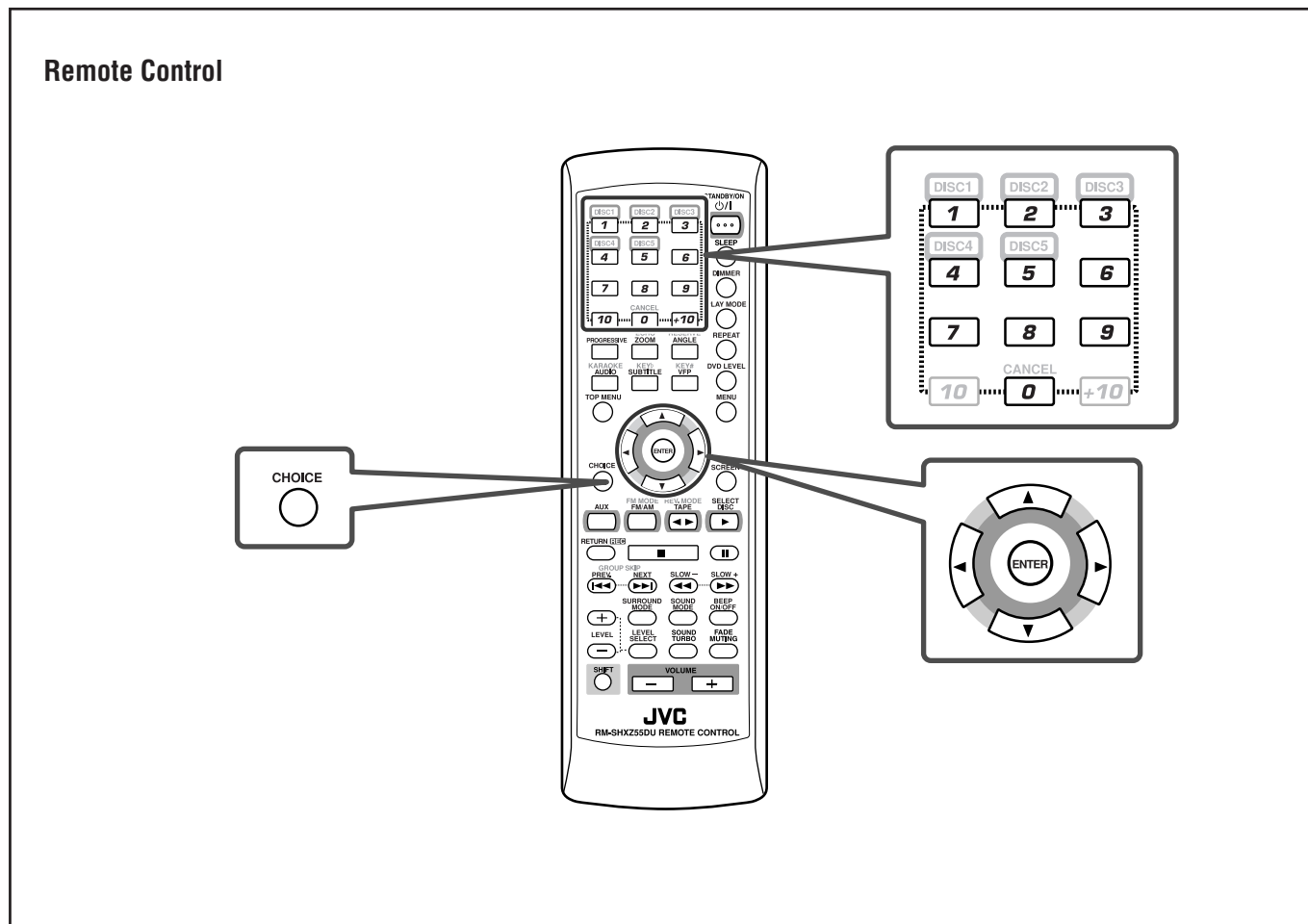

This section explains the choice menu operations by using the remote control.

- Turn on your TV and select the correct input mode on the TV.

If “⊘” appears on the TV when you press a button, the disc cannot accept an operation you have tried to do, or data required for that operation is not recorded on the disc.

Choice Menu Operations (continued)

You can adjust the initial settings through the choice menu on the TV.

You can use the choice menu only when the selected source is disc player and its playback is not started.

Before operating...

- Turn on your TV and select the correct input mode on the TV.
- You can use only the remote control for the choice menu operations.
- You can change the language used in the choice menu. See page 61.



When you operate choice menu

The SURROUND indicator lights up and the Surround mode is canceled temporarily. This is not malfunction.

Introducing the Choice Menus

■ Operation buttons

On the remote control ONLY:

Button	To do
CHOICE	Display the choice menu on the TV. Each time you press the button, the choice menu is turned on and off alternately.
▶/◀	Change the choice menu.
▲/▼	Select an item on a choice menu or select an option for selected item.
ENTER	Move to the submenu of the selected item or confirm the setting.

About menu icons

The icon for the selected choice menu will be highlighted.

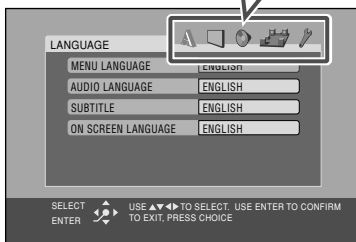
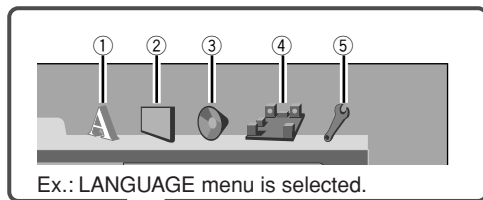

- ① LANGUAGE menu
- ② PICTURE menu
- ③ AUDIO menu
- ④ SPK. SETTING menu
- ⑤ OTHERS menu

For details on each choice menu, see "Configuration of choice menus" on the right column.

■ Configuration of the choice menus

The choice menu has the following menus:

LANGUAGE menu (see page 61)

You can select the initial language for the disc menu, audio, and subtitle. You can also select the language shown on the TV screen while operating this unit.

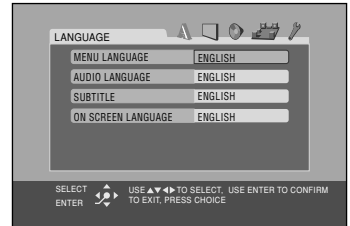

PICTURE menu (see page 61)

You can select the desired options concerning a picture or monitor screen.



AUDIO menu (see page 62)

You can adjust the sound settings of this unit through this menu.

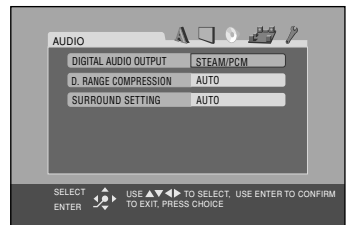

SPK. SETTING menu (see page 63)

You can adjust the speaker settings. You can also adjust the output level of the speakers.

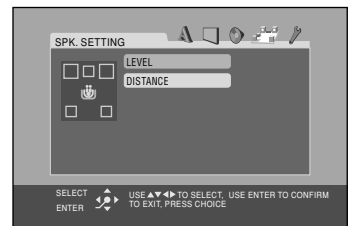

OTHERS menu (see page 63)

You can change the settings for some of the functions. To set Parental Lock, use this menu.

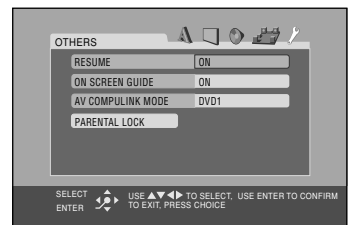

Operating Procedure

Make sure that the disc player is selected for the source.

Ex.: When setting MP3/JPEG.

1 Press CHOICE.

The LANGUAGE menu appears on the TV.

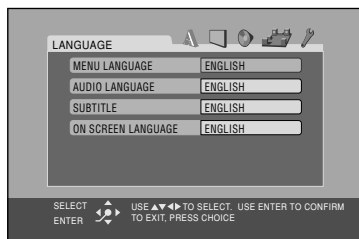

2 Press cursor ► / ◀ repeatedly to display the PICTURE menu.

- Each time you press the button, the menu changes.

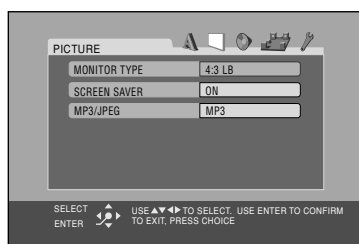

3 Press cursor ▼ / ▲ repeatedly to select (highlight) “MP3/JPEG.”

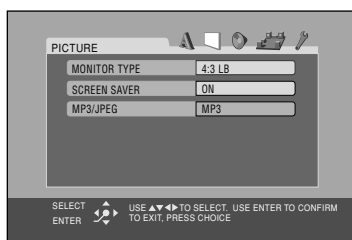

4 Press ENTER.

The pop-up window listing the selectable options appears.

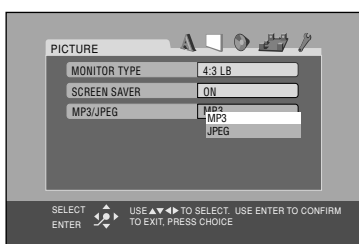

5 Press cursor ▼ / ▲ repeatedly to select (highlight) the desired option.

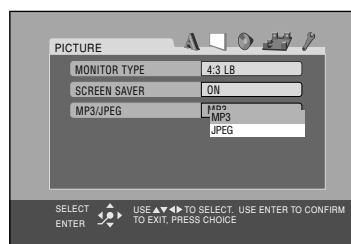

Ex.: When “JPEG” is selected.

6 Press ENTER to finish the setting.

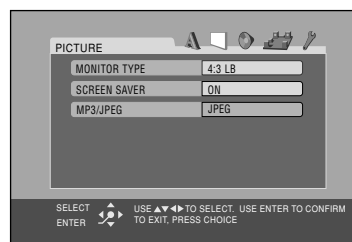

To set other items on the same choice menu

Repeat steps 3 to 6.

To move to another choice menu

Press cursor ► / ◀ repeatedly to select (highlight) a choice menu you want to set up.

To return to the normal screen

Press CHOICE.

To enter submenus

Some items in the choice menu consist of submenus for setting up various options. Pressing ENTER shows the submenus for the selected item on the TV.

- You can set the items using cursor ▲/▼ and ENTER (as explained in steps 5 and 6 above).

Choice Menu Operations (continued)

■ Language selection menu—LANGUAGE

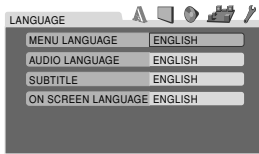

You can select “MENU LANGUAGE,” “AUDIO LANGUAGE,” and “SUBTITLE” only before playback.

• MENU LANGUAGE

Some discs have multiple menu languages.

Select one of the languages or language codes from AA to ZU (see “Language Code List” on page 68).

• AUDIO LANGUAGE

Some discs have multiple audio languages.

Select one of the languages or language codes from AA to ZU (see “Language Code List” on page 68).

• SUBTITLE

Some discs have multiple subtitle languages.

Select one of the languages or language codes from AA to ZU (see “Language Code List” on page 68) or “OFF (no subtitle).”

• ON SCREEN LANGUAGE

Select one of the languages shown on the TV. Selectable languages—ENGLISH, Chinese (中国語), and Spanish (ESPAÑOL)



When the language you have selected for MENU LANGUAGE, AUDIO LANGUAGE, or SUBTITLE is not recorded on a disc

The original language is used as the initial language.

■ Picture setting menu—PICTURE

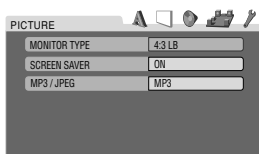

• MONITOR TYPE

You can select the monitor type of your TV when you play DVD VIDEO recorded with aspect ratio of 16:9.

Select one of the following settings:

16:9 NORMAL (Wide television conversion)

Select when the aspect ratio of your TV is fixed to 16:9 (wide TV). The unit automatically adjusts the screen width of the output signal correctly when playing back a picture whose aspect ratio is 4:3.

16:9 AUTO (Wide television conversion)

Select when the aspect ratio of your TV is 16:9 (wide TV) and when the TV has the screen size adjustment function.

4:3 LB (Letter Box conversion)

Select when the aspect ratio of your TV is 4:3 (conventional TV). While viewing a wide screen picture, the black bars appear on the top and the bottom of the screen.

4:3 PS (Pan Scan conversion)

Select when the aspect ratio of your TV is 4:3 (conventional TV). While viewing a wide screen picture, the black bars do not appear; however, the left and right edges of the pictures will not be shown on the screen.

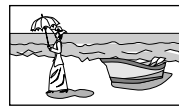

Ex.: 16:9



Ex.: 4:3 LB

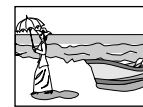

Ex.: 4:3 PS

- Even if “4:3 PS” is selected, the screen size may become 4:3 letter box with some DVD VIDEOS. This depends on how the discs are recorded.
- When you select “16:9 NORMAL” for a picture whose aspect ratio is 4:3, the picture slightly changes due to the process for converting the picture width.

• SCREEN SAVER

You can activate or deactivate the screen saver function while operating the disc player.

Select one of the following settings:

ON The picture on the TV becomes dark when no operation is done for 5 minutes.

OFF The screen saver function does not work.

• MP3/JPEG

If both MP3 files and JPEG files are recorded on a disc, you can select which files to play.

Select one of the following settings:

MP3 Select for playing MP3 files.

JPEG Select for playing JPEG files.



When you change the setting while playing back a disc contains both MP3 files and JPEG files

The setting will not take effect until you open and close the disc tray for the current disc or select another disc tray to play.

■ Audio selection menu—AUDIO

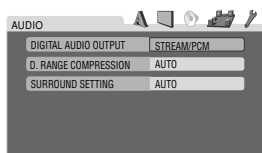

You can select “DIGITAL AUDIO OUTPUT,” “D. RANGE COMPRESSION,” and “SURROUND SETTING” only before playback.

• DIGITAL AUDIO OUTPUT

To connect the unit’s digital output to an external device equipped with a digital input, this item must be set correctly. See “Output Signals through the OPTICAL DIGITAL OUTPUT Terminal” on page 68 for details about the relation between the setting and output signals.

Select one of the following settings:

PCM ONLY

Select when you connect to the linear PCM digital input terminal of other audio equipment.

DOLBY DIGITAL/PCM

Select when you connect to the digital input terminal of a Dolby Digital decoder or an amplifier with a built-in Dolby Digital decoder.

STREAM/PCM

Select when you connect the digital input terminal of an amplifier with a built-in MPEG Multichannel, DTS, or Dolby Digital decoder, or the stand-alone unit of such a decoder.

• D. (dynamic) RANGE COMPRESSION

You can compress the dynamic range (the difference of the loudest sound to the softest sound) to enjoy a powerful sound even at a low volume level when listening to Dolby Digital software. This is useful when enjoying the Surround sound at night. The effectiveness varies depends on a software.

Select one of the following settings:

- AUTO**
- When SURROUND SETTING is set to “OFF” Applies the compression effect to the mixed-down multi-channel sound.
 - When SURROUND SETTING is set to “AUTO” or “ON” Any compression effect will not be applied to the multi-channel sound. You can enjoy the original surround sound.

- ON** Applies the compression effect. Select to always use this function for all Dolby digital software. Loud sound will become low and vice versa.

• SURROUND SETTING

You can enjoy the Surround mode simply by playing back a disc when the surround setting is in use—“AUTO” or “ON.” This setting takes effect only when the source is disc player. This setting does not affect DIGITAL AUDIO OUTPUT setting.

Select one of the following settings:

- AUTO**
- If Dolby Digital or DTS multi-channel software is played back, the corresponding Surround mode will be turned on automatically.
 - If Dolby Surround signal comes in, Dolby Pro Logic will be turned on.
 - If Linear PCM (used for CD, SVCD, VCD and some DVDs), MPEG Multichannel, or MP3 sound is played back, the Surround mode will be turned off.
- ON**
- If multi-channel software is played back, the corresponding Surround mode—Dolby Digital or DTS—will be turned on automatically.
 - If 2-channel software is played back, Dolby Pro Logic will be turned on.
- OFF** The Surround mode will be deactivated for all discs. (The multi-channel signal is mixed down to 2-channel signal.)

Surround setting and available Surround mode

Surround setting \ Signal	AUTO	ON	OFF
Multi-channel			
Dolby Digital	Dolby Digital	Dolby Digital	STEREO*
DTS	DTS	DTS	
MPEG Multichannel	STEREO*	Dolby Pro Logic	
2-channel			
Dolby Digital	STEREO*	Dolby Pro Logic	STEREO*
Dolby surround	Dolby Pro Logic		
DTS	STEREO*		
MPEG Multichannel			
Linear PCM			
MP3			

- * If one of the DSP modes has been activated previously, it will be activated again. Surround setting will be restored in the following cases:
- When you turn the unit off and on, or
 - When you select disc player again from another source.



When connecting a pair of headphones

The Surround mode will be canceled temporarily (“STEREO” will appear on the display).

Choice Menu Operations (continued)

■ Speaker setting menu—SPK. SETTING

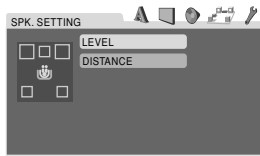

Speaker diagrams

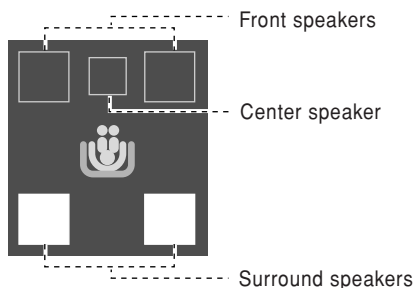

• LEVEL

Select this to enter the LEVEL submenu.

If the output sound of center speaker or surround speakers from the listening position are not equal to that of the front speakers, use test tone to adjust the output level to get the best possible surround effect.

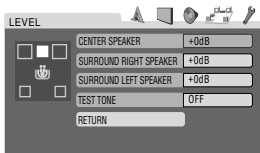

1. Select “**ON**” of the item **TEST TONE**.
2. Select the speaker—**CENTER SPEAKER, SURROUND RIGHT SPEAKER, SURROUND LEFT SPEAKER**.
3. Adjust the speaker output level for the selected speaker.
You can adjust the output level within the range of -6 dB to $+6$ dB in 1 dB interval.
4. Repeat steps 2 and 3 to adjust the other speakers.
 - To stop test tone, select “**OFF**” of the item **TEST TONE**.
5. Select “**RETURN**” then press ENTER to return to the SPK. SETTING menu.

• DISTANCE

Select this to enter the DISTANCE submenu.

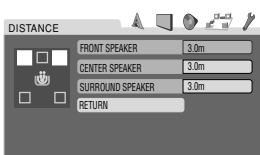

FRONT SPEAKER, CENTER SPEAKER, and SURROUND SPEAKER

For each speaker, set the distance from the listening point within the range of 0.3 m to 9.0 m in 0.3 m intervals.

RETURN

Select this then press ENTER to return to the SPK. SETTING menu.

■ Other setting menu—OTHERS

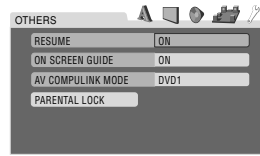

• RESUME

You can activate or deactivate the resume play function of the built-in disc player.

- You cannot use Resume Play for all CD/MP3/JPEG discs and some DVD/SVCD/VCD discs.
- Resume Play may not be able to use with some DVDs, SVCDs and VCDs.

Select one of the following settings:

ON Select to activate this function.

OFF Select to deactivate it.

• ON SCREEN GUIDE

You can activate or deactivate the on-screen guide icons (see page 36).

The on-screen guide icons appear on the TV at the beginning of the playback with this function turned on.

When recording the picture on a VCR, select “OFF” to avoid recording the indications on your video tape.

- The choice menu and on-screen bar will be displayed (and recorded) even though this function is set to “OFF.” Subtitles and the information for zooming in (see pages 40 and 42) always appear on the display regardless of this setting.

Select one of the following settings:

ON Select to activate this function.

OFF Select to deactivate it.

• AV COMPULINK MODE

When connecting this unit to a JVC’s TV with the AV COMPULINK remote control system, select the proper setting.

Select one of the following settings:

DVD1 Select when you connect this unit to the COMPONENT VIDEO (or VIDEO-3) terminals on a TV using a component video cord.

DVD2 Select when you connect this unit to the VIDEO-1 terminals on a TV using an S-video cord.

DVD3 Select when you connect this unit to the VIDEO-2 terminals on a TV using a composite video cord.

For AV COMPU LINK control system, see page 67.

• PARENTAL LOCK

You can restrict playback of DVD VIDEO containing violent scenes and those not suitable for your family members.

- You can select “PARENTAL LOCK” only before playback.

Select this to enter the PARENTAL LOCK submenu. (See pages 64 to 66.)

Restricting the Access Level—Parental Lock

You can restrict playback of DVD VIDEO containing violent scenes and those unsuitable for your family members. Nobody can play such a disc unless this function is canceled.

- You can set the Parental Lock only while a disc is not playing.
- This setting takes effect only for a DVD VIDEO containing Parental Lock level information—Level 1 (most restrictive) to Level 8 (least restrictive).

Playback of discs containing higher level than the selected level will be restricted. Some discs may not be played back at all, and others may be played back with higher level scenes skipped.

Ex.: When you select “4,” discs containing level 5, 6, 7, or 8 can be played back.

■ Setting Parental Lock

1 Press **CHOICE**, then press cursor **▶** / **◀** to display the **OTHERS** menu.

2 Press cursor **▼** / **▲** repeatedly to select (highlight) “**PARENTAL LOCK**,” then press **ENTER**.

The **PARENTAL LOCK** submenu appears on the TV.

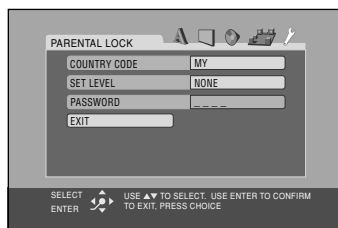

3 Press cursor **▼** / **▲** repeatedly to select (highlight) “**COUNTRY CODE**,” then press **ENTER**.

The pop-up window for setting the country code appears.

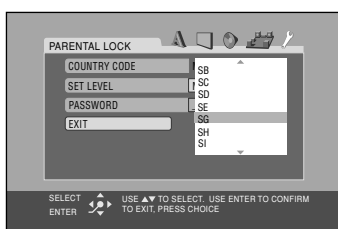

- See “Country/Area codes list for Parental Lock” on page 66.

4 Press cursor **▼** / **▲** repeatedly to select (highlight) the country code, then press **ENTER**.

“**SET LEVEL**” is now selected (highlighted).

5 Press **ENTER**.

The pop-up window for level setting appears.

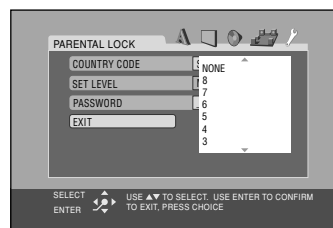

6 Press cursor **▼** / **▲** repeatedly to select (highlight) the level of restriction, then press **ENTER**.

- The smaller the value of level is, the more restrictive the Parental Lock level is.
- Select “**NONE**” to cancel this function.

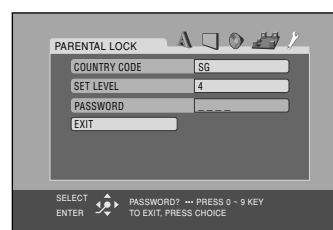

7 Press the number buttons (**0 – 9**) to enter a four digit number for your password, then press **ENTER**.

“**EXIT**” is now selected (highlighted).

8 Press **ENTER**.

The **OTHERS** menu resumes.

To return to the normal screen
Press **CHOICE**.



Remember your password or make a note of it

You need to enter your password to change the setting or release the lock. To change the setting, see page 65.

Choice Menu Operations (continued)

■ Changing the Parental Lock setting

- 1** Press **CHOICE**, then press cursor **▶** / **◀** to display the **OTHERS** menu.
- 2** Press cursor **▼** / **▲** repeatedly to select (highlight) **“PARENTAL LOCK,”** then press **ENTER**.

The PARENTAL LOCK submenu appears on the TV.

- You can only select **“PASSWORD”** or to **“EXIT”** before you enter your password.

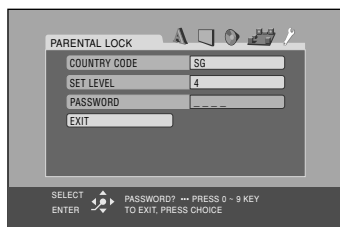

- 3** Press the number buttons **(0 – 9)** to enter your password, then press **ENTER**.
 - If you enter a wrong password, **“WRONG! RETRY... PRESS 0~9KEY”** appears on the TV. You cannot go to next steps before you enter the correct password.
- 4** Press cursor **▼** / **▲** repeatedly to select (highlight) the item you want to change, then press **ENTER**.
- 5** Press cursor **▼** / **▲** repeatedly to change the setting, then press **ENTER**.
- 6** Press the number buttons **(0 – 9)** to enter a four digit number for your password, then press **ENTER**.
 - When you want to change the password, enter the new password in this step.
- 7** Press **ENTER**.

The new setting is stored.



- You cannot change the Parental Lock before you enter your password.
- If you exit from the PARENTAL LOCK submenu before entering your password in step **6**, the new country code and parental level will not become effective, and the previous country code and parental level remain effective.
- When you enter wrong passwords three times, **“EXIT”** will be selected (highlight) automatically and cursor **▼** / **▲** does not work. Press **ENTER** to exit from the PARENTAL LOCK submenu, then start from step **1** again.
- If you forget your password, enter **“8888.”**

■ Releasing Parental Lock temporarily

When you set a strict parental level, some discs may not be played back at all. When you load such a disc and try to play it, the following display appears on the TV. You can release Parental Lock temporarily.

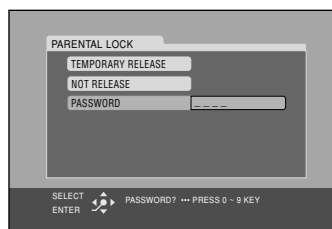

- 1** Press cursor **▼** / **▲** repeatedly to select (highlight) **“TEMPORARY RELEASE,”** then press **ENTER**.

“PASSWORD” is now selected (highlighted).

 - If you do not want to release Parental Lock temporarily, select **“NOT RELEASE”** by pressing cursor **▼** / **▲**, then press **ENTER**. To eject the disc, press **▲** for the disc tray.
- 2** Press number buttons **(0 – 9)** to enter your password, then press **ENTER**.

Playback starts.

 - If you enter a wrong password, **“WRONG! RETRY... PRESS 0~9KEY”** appears on the screen. You cannot play the disc before you enter the correct password.



When you enter wrong passwords three times **“NOT RELEASE”** will be selected (highlighted) automatically and cursor **▼** / **▲** does not work. Press **▲** for the disc tray to remove the disc.

Country/Area codes list for Parental Lock

AD	Andorra	ER	Eritrea	LA	Lao People's Democratic Republic	RW	Rwanda
AE	United Arab Emirates	ES	Spain			SA	Saudi Arabia
AF	Afghanistan	ET	Ethiopia	LB	Lebanon	SB	Solomon Islands
AG	Antigua and Barbuda	FI	Finland	LC	Saint Lucia	SC	Seychelles
AI	Anguilla	FJ	Fiji	LI	Liechtenstein	SD	Sudan
AL	Albania	FK	Falkland Islands (Malvinas)	LK	Sri Lanka	SE	Sweden
AM	Armenia	FM	Micronesia (Federated States of)	LR	Liberia	SG	Singapore
AN	Netherlands Antilles			LS	Lesotho	SH	Saint Helena
AO	Angola	FO	Faroe Islands	LT	Lithuania	SI	Slovenia
AQ	Antarctica	FR	France	LU	Luxembourg	SJ	Svalbard and Jan Mayen
AR	Argentina	FX	France, Metropolitan	LV	Latvia	SK	Slovakia
AS	American Samoa	GA	Gabon	LY	Libyan Arab Jamahiriya	SL	Sierra Leone
AT	Austria	GB	United Kingdom	MA	Morocco	SM	San Marino
AU	Australia	GD	Grenada	MC	Monaco	SN	Senegal
AW	Aruba	GE	Georgia	MD	Moldova, Republic of	SO	Somalia
AZ	Azerbaijan	GF	French Guiana	MG	Madagascar	SR	Suriname
BA	Bosnia and Herzegovina	GH	Ghana	MH	Marshall Islands	ST	Sao Tome and Principe
BB	Barbados	GI	Gibraltar	ML	Mali	SV	El Salvador
BD	Bangladesh	GL	Greenland	MM	Myanmar	SY	Syrian Arab Republic
BE	Belgium	GM	Gambia	MN	Mongolia	SZ	Swaziland
BF	Burkina Faso	GN	Guinea	MO	Macau	TC	Turks and Caicos Islands
BG	Bulgaria	GP	Guadeloupe	MP	Northern Mariana Islands	TD	Chad
BH	Bahrain	GQ	Equatorial Guinea	MQ	Martinique	TF	French Southern Territories
BI	Burundi	GR	Greece	MR	Mauritania	TG	Togo
BJ	Benin	GS	South Georgia and the South Sandwich	MS	Montserrat	TH	Thailand
BM	Bermuda			MT	Malta	TJ	Tajikistan
BN	Brunei Darussalam	GT	Guatemala	MU	Mauritius	TK	Tokelau
BO	Bolivia	GU	Guam	MV	Maldives	TM	Turkmenistan
BR	Brazil	GW	Guinea-Bissau	MW	Malawi	TN	Tunisia
BS	Bahamas	GY	Guyana	MX	Mexico	TO	Tonga
BT	Bhutan	HK	Hong Kong	MY	Malaysia	TP	East Timor
BV	Bouvet Island	HM	Heard Island and McDonald Islands	MZ	Mozambique	TR	Turkey
BW	Botswana			NA	Namibia	TT	Trinidad and Tobago
BY	Belarus	HN	Honduras	NC	New Caledonia	TV	Tuvalu
BZ	Belize	HR	Croatia	NE	Niger	TW	Taiwan
CA	Canada	HT	Haiti	NF	Norfolk Island	TZ	Tanzania, United Republic of
CC	Cocos (Keeling) Islands	HU	Hungary	NG	Nigeria		
CF	Central African Republic	ID	Indonesia	NI	Nicaragua	UA	Ukraine
CG	Congo	IE	Ireland	NL	Netherlands	UG	Uganda
CH	Switzerland	IL	Israel	NO	Norway	UM	United States Minor Outlying Islands
CI	Côte d'Ivoire	IN	India	NP	Nepal		
CK	Cook Islands	IO	British Indian Ocean Territory	NR	Nauru	US	United States
CL	Chile			NU	Niue	UY	Uruguay
CM	Cameroon	IQ	Iraq	NZ	New Zealand	UZ	Uzbekistan
CN	China	IR	Iran (Islamic Republic of)	OM	Oman	VA	Vatican City State (Holy See)
CO	Colombia	IS	Iceland	PA	Panama		
CR	Costa Rica	IT	Italy	PE	Peru	VC	Saint Vincent and the Grenadines
CU	Cuba	JM	Jamaica	PF	French Polynesia		
CV	Cape Verde	JO	Jordan	PG	Papua New Guinea	VE	Venezuela
CX	Christmas Island	JP	Japan	PH	Philippines	VG	Virgin Islands (British)
CY	Cyprus	KE	Kenya	PK	Pakistan	VI	Virgin Islands (U.S.)
CZ	Czech Republic	KG	Kyrgyzstan	PL	Poland	VN	Vietnam
DE	Germany	KH	Cambodia	PM	Saint Pierre and Miquelon	VU	Vanuatu
DJ	Djibouti	KI	Kiribati	PN	Pitcairn	WF	Wallis and Futuna Islands
DK	Denmark	KM	Comoros	PR	Puerto Rico	WS	Samoa
DM	Dominica	KN	Saint Kitts and Nevis	PT	Portugal	YE	Yemen
DO	Dominican Republic	KP	Korea, Democratic	PW	Palau	YT	Mayotte
DZ	Algeria		People's Republic of	PY	Paraguay	YU	Yugoslavia
EC	Ecuador	KR	Korea, Republic of	QA	Qatar	ZA	South Africa
EE	Estonia	KW	Kuwait	RE	Réunion	ZM	Zambia
EG	Egypt	KY	Cayman Islands	RO	Romania	ZR	Zaire
EH	Western Sahara	KZ	Kazakhstan	RU	Russian Federation	ZW	Zimbabwe

Additional Information

Using AV COMPU LINK Control System

The AV COMPU LINK control system allows you to use JVC's TV with simple operations.

To use AV COMPU LINK control system, you need to connect this unit and a TV through the AV COMPU LINK terminals.

- You can connect to a TV that has AV COMPU LINK II, AV COMPU LINK III or AV COMPU LINK EX terminals.

AV COMPU LINK connection

Connect a TV by using a video cord (see page 8) then also connect it by using a cord with monaural mini-plugs (not supplied).

- You need to set "AV COMPULINK MODE" correctly to use AV COMPU LINK control system. (See page 63.)

Set the "AV COMPULINK MODE" to

- "DVD 1" when you connect this unit to the COMPONENT VIDEO (or VIDEO-3) terminals on a TV using a component video cord.
- "DVD 2" when you connect this unit to the VIDEO-1 terminals on a TV using an S-video cord.
- "DVD 3" when you connect this unit to the VIDEO-2 terminals on a TV using a composite video cord.

Available operations

You can use following functions by using AV COMPU LINK control system.

One-touch DVD play

Simply by start playing back the unit, the TV automatically turns on and changes the input mode to the appropriate position so that you can view the playback picture.

- The TV does not turn off automatically even if you turn off the unit.



When the main power of the TV is turned off or the power cord of the TV is unplugged

You cannot use the one-touch play.

Connection diagram

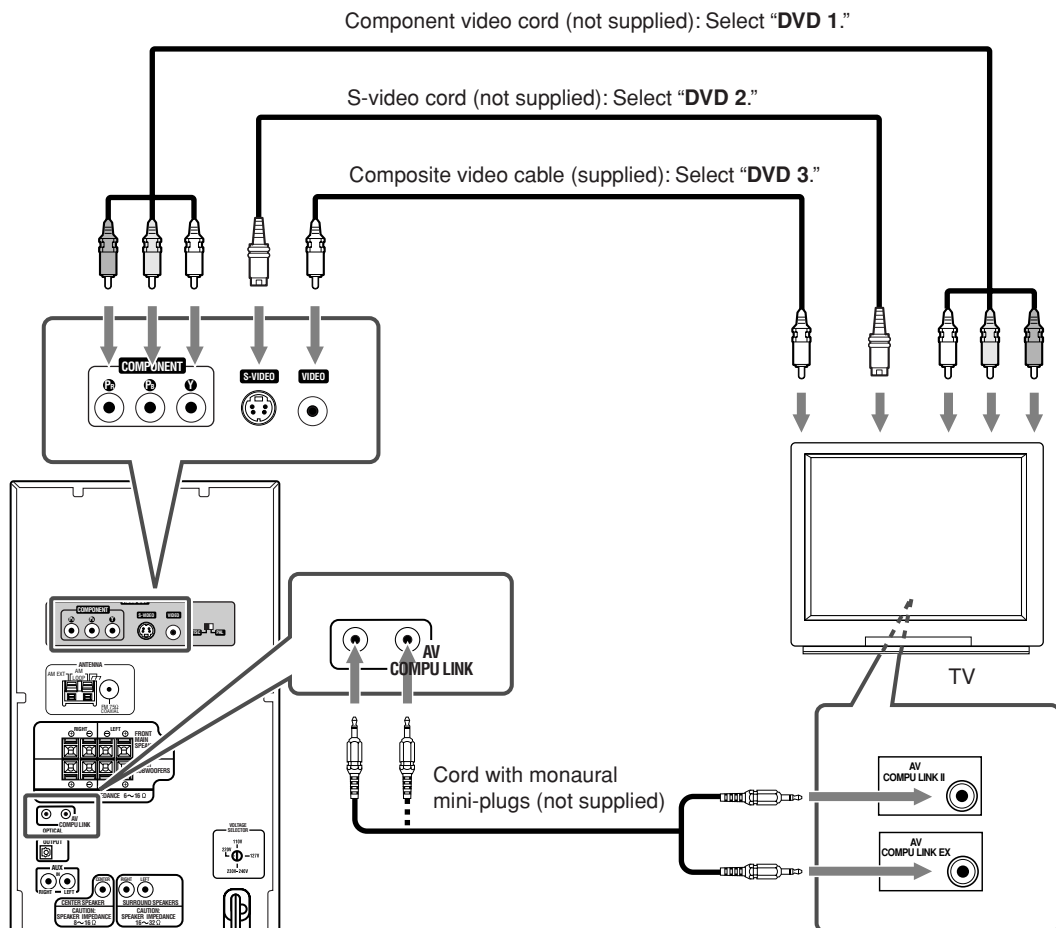

Output Signals through the OPTICAL DIGITAL OUTPUT Terminal

Output signals differ according to the “DIGITAL AUDIO OUTPUT” setting. (See page 62.)

DIGITAL AUDIO OUTPUT Playback disc	Output Signals		
	STREAM/PCM	DOLBY DIGITAL/PCM	PCM ONLY
DVD with 48 kHz, 16/20/24 bit Linear PCM	48 kHz, 16 bit Linear PCM*		
with 96 kHz, Linear PCM	48 kHz, Linear PCM		
with Dolby Digital	Dolby Digital bitstream		48 kHz, Linear PCM
with DTS Digital Surround	DTS bitstream		
with MPEG Audio	MPEG bitstream	48 kHz, Linear PCM	
SVCD, VCD, CD	44.1 kHz, 16 bit Linear PCM		
CD with DTS Digital Surround	DTS bitstream	44.1 kHz, 16 bit Linear PCM	

- * While playing some DVDs, digital signals may be emitted at 20 bits or 24 bits (at their original bit rate) through the OPTICAL DIGITAL OUTPUT terminal if the discs are not copy-protected.
- No signal is emitted through the OPTICAL DIGITAL OUTPUT terminal while playing an MP3 disc.

Language Code List

AA	Afar	FA	Persian	KM	Cambodian	OM	(Afan) Oromo	SU	Sundanese
AB	Abkhazian	FI	Finnish	KN	Kannada	OR	Oriya	SV	Swedish
AF	Afrikaans	FJ	Fiji	KO	Korean (KOR)	PA	Panjabi	SW	Swahili
AM	Ameharic	FO	Faroese	KS	Kashmiri	PL	Polish	TA	Tamil
AR	Arabic	FY	Frisian	KU	Kurdish	PS	Pashto, Pushto	TE	Telugu
AS	Assamese	GA	Irish	KY	Kirghiz	PT	Portuguese	TG	Tajik
AY	Aymara	GD	Scots Gaelic	LA	Latin	QU	Quechua	TH	Thai
AZ	Azerbaijani	GL	Galician	LN	Lingala	RM	Rhaeto-Romance	TI	Tigrinya
BA	Bashkir	GN	Guarani	LO	Laothian	RN	Kirundi	TK	Turkmen
BE	Byelorussian	GU	Gujarati	LT	Lithuanian	RO	Rumanian	TL	Tagalog
BG	Bulgarian	HA	Hausa	LV	Latvian, Lettish	RU	Russian	TN	Setswana
BH	Bihari	HI	Hindi	MG	Malagasy	RW	Kinyarwanda	TO	Tonga
BI	Bislama	HR	Croatian	MI	Maori	SA	Sanskrit	TR	Turkish
BN	Bengali, Bangla	HU	Hungarian	MK	Macedonian	SD	Sindhi	TS	Tsonga
BO	Tibetan	HY	Armenian	ML	Malayalam	SG	Sangho	TT	Tatar
BR	Breton	IA	Interlingua	MN	Mongolian	SH	Serbo-Croatian	TW	Twi
CA	Catalan	IE	Interlingue	MO	Moldavian	SI	Singhalese	UK	Ukrainian
CO	Corsican	IK	Inupiak	MR	Marathi	SK	Slovak	UR	Urdu
CS	Czech	IN	Indonesian	MS	Malay (MAY)	SL	Slovenian	UZ	Uzbek
CY	Welsh	IS	Icelandic	MT	Maltese	SM	Samoan	VI	Vietnamese
DA	Danish	IW	Hebrew	MY	Burmese	SN	Shona	VO	Volapuk
DZ	Bhutani	JL	Yiddish	NA	Nauru	SO	Somali	WO	Wolof
EL	Greek	JW	Javanese	NE	Nepali	SQ	Albanian	XH	Xhosa
EO	Esperanto	KA	Georgian	NL	Dutch	SR	Serbian	YO	Yoruba
ET	Estonian	KK	Kazakh	NO	Norwegian	SS	Siswati	ZU	Zulu
EU	Basque	KL	Greenlandic	OC	Occitan	ST	Sesotho		

Additional Information (continued)

Glossary

Aspect ratio

The ratio of vertical and horizontal sizes of a displayed image. The horizontal vs. vertical ratio of conventional TVs is 4:3 and that of wide-screen TVs is 16:9.

Component video signal

A video signal system where elements necessary for reproducing image signal comprised of the three primary colors of light are transmitted via separate signal lines. Types of signal, such as R/G/B, Y/P_B/P_R, etc., are available.

Composite video signal

A video signal comprised of three kinds of signals combined: an image signal made up of luminance and chrominance signals using the frequency multiplication technique, burst signal providing the basis for color reproduction, and synchronization signal.

Dolby Digital

This is a digital audio compression technology that was developed by Dolby Laboratories. Dolby Digital encoding method (so-called discrete 5.1 channel digital audio format) records and compresses the left front channel, right front channel, center channel, left rear channel, right rear channel, and LFE channel (total 6 channels, but LFE channel is counted as 0.1 channel, therefore called 5.1 channels) signals digitally. Each channel is completely independent from other channel signals to avoid interference, therefore, you can obtain much better sound quality with stereo and surround effects.

Dolby Pro Logic

Dolby Surround encoding format records the left front channel, right front channel, center channel, and surround channel (monaural) signals into 2 channels. The Dolby Pro Logic decoder built in this unit decodes these 2 channel signals into 4 original channel signals—matrix-based multi-channel reproduction.

DTS Digital Surround

Another discrete 5.1 channel digital audio format, available on CD, LD, and DVD software, developed by Digital Theater Systems, Inc. Compared to Dolby Digital, audio compression rate is relatively low. This fact allows DTS Digital Surround format to add breadth and depth to the reproduced sounds. As a result, DTS Digital Surround features natural, solid and clear sound.

Interlaced scanning

In the conventional video system, a picture is shown on the display monitor in two halves. The Interlaced scanning system places lines of the second half of the picture in-between lines of the first half of the picture.

JPEG

A still-picture data compression system proposed by the Joint Photographic Expert Group, which features little distortion in image quality in spite of its high compression ratio.

Letter box

A method of displaying wide images like movies in on a 4:3 TV screen with no part of the image deleted by placing black bands on the top and bottom of the screen. This name has derived from the screen form looking literally like a letter box.

MPEG Multichannel

Digital audio compression format used for PAL/SECAM DVD software. (MPEG stands for “Moving Picture Experts Group” and has been originally developed for compressing video signals.) To reproduce these original surround signals, you need to connect an amplifier or a decoder compatible with MPEG Multichannel.

MP3

A file format with a sound data compression system. “MP3” is the abbreviation of Motion Picture Experts Group 1 (or MPEG-1) Audio Layer 3. By using MP3 format, one CD-R or CD-RW can contain about 10 times as much data volume as a regular CD can.

Multi-angle

By recording multiple scenes progressing at the same time in a single title, the user can select view angles. This feature is called the multi-angle function.

Multi-channel

DVD VIDEO has been designed to have each soundtrack constitute one sound field. Multi-channel refers to a structure of sound tracks having three or more channels.

Multi-language

When a title is created to cope with multiple languages, it is generally called a multilanguage title.

Playback control (PBC)

Refers to the signal recorded on SVCD/VCD for controlling reproduction. By using menu screens recorded on SVCD/VCD that supports PBC, you can enjoy interactive-type software as well as software having a search function.

Progressive scanning

By progressive scanning, all the horizontal lines of a picture are displayed at one time as a single frame on a TV compatible with NTSC color system. This system can convert the interlaced video from DVD VIDEO into progressive format for a progressive TV. It dramatically increases the vertical resolution.

Region code

A system for allowing discs to be played only in the regions designated beforehand. All the countries in the world are divided into six regions and each region is identified by a specified region code (or region number). If the region code of a disc matches to that of a player, the player can play back the disc.

Sampling frequency

Frequency of sampling data when analog data is converted to digital data. Sampling frequency numerically represents how many times the original analog signal is sampled per second.

Transfer rate

The rate of transferring digital data. Usually the measure is in bit per second (bps). The DVD system applies a variable transfer rate system for high efficiency.

Maintenance

To get the best performance of the unit, keep your discs, tapes, and mechanism clean.

Handling discs



- Remove the disc from its case by holding it at the edge while pressing the center hole lightly.
- Do not touch the shiny surface of the disc, or bend the disc.
- Put the disc back in its case after use to prevent warping.

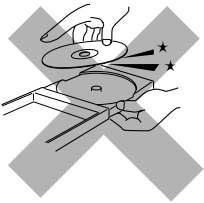

- Be careful not to scratch the surface of the disc when placing it back in its case.
- Avoid exposure to direct sunlight, temperature extremes, and moisture.

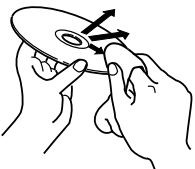

To clean the disc

Wipe the disc with a soft cloth in a straight line from center to edge.

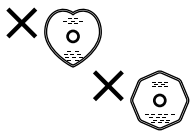

Continued use of irregular shape discs (heart-shape, octagonal, etc.) can damage the unit.



DO NOT use any solvent—such as conventional record cleaner, spray, thinner, or benzine—to clean the disc.

To keep the best recording and playback sound quality

If the heads, capstans, and pinch rollers of the cassette deck become dirty, the following will occur:

- Impaired sound quality
- Discontinuous sound
- Fading
- Incomplete erasure
- Difficulty in recording

To clean the heads, capstans, and pinch rollers

Use a cotton swab moistened with alcohol.

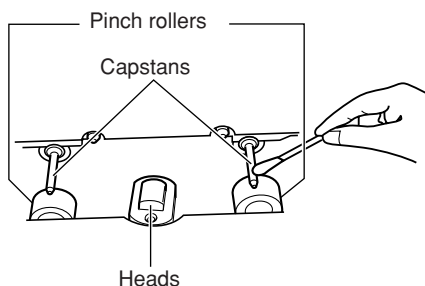

To demagnetize the heads

Turn off the unit, and use a head demagnetizer (available at electronics and audio shops).

Handling cassette tapes

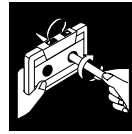

- If the tape is loose in its cassette, take up the slack by inserting a pencil in one of the reels and rotating.
- If the tape is loose, it may get stretched, cut, or caught in the cassette.



- Be careful not to touch the tape surface.

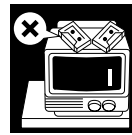

- Avoid the following places to store the tape:
 - In dusty places
 - In direct sunlight or heat
 - In moist areas
 - Near a magnet

Cleaning the unit

• Stains on the unit

Should be wiped off with a soft cloth. If the unit is heavily stained, wipe it with a cloth soaked in water diluted neutral detergent and wrung well, then wipe clean with a dry cloth.

• Since the unit may deteriorate in quality, become damaged or get its paint peeled off, be careful about the followings.

- DO NOT wipe it with a hard cloth.
- DO NOT wipe it strong.
- DO NOT wipe it with thinner or benzine.
- DO NOT apply any volatile substance such as insecticides to it.
- DO NOT allow any rubber or plastic to remain in contact with it for a long time.

Additional Information (continued)

Troubleshooting

If you are having a problem with your unit, check this list for a possible solution before calling for service.

If you cannot solve the problem from the hints given here, or the unit has been physically damaged, call a qualified person, such as your dealer, for service.

Symptom	Cause	Action
Display demonstration automatically restarts in certain intervals.	The display demonstration is not yet canceled.	Press CANCEL/DEMO on the front panel. (See page 10.)
No sound is heard.	Connections are incorrect or loose.	Check all connections and make corrections. (See pages 6 to 10.)
Hard to listen to broadcasts because of noise.	Antennas are disconnected.	Reconnect the antennas correctly and securely.
	<ul style="list-style-type: none"> The AM loop antenna is too close to the unit. The FM antenna is not properly extended and positioned. 	<ul style="list-style-type: none"> Change the position and direction of the AM loop antenna. Extend the FM antenna at the best position.
The disc sound is discontinuous.	The disc is scratched or dirty.	Clean or replace the disc. (See page 70.)
Disc tray does not open or close.	The AC power cord is not plugged in.	Plug the AC power cord.
	Trays are locked.	Unlock the trays. (See page 17.)
The disc does not play.	The disc is placed upside down.	Place the disc with the label side up.
Impossible to turn off Dolby Pro Logic while playing back a disc.	“ON” is selected as SURROUND SETTING.	Change the SURROUND SETTING to “AUTO” or “OFF.” (See page 62.)
No picture appears on the screen.	The video cord is not connected correctly.	Connect the video cord correctly.
	Incorrect color system is selected.	Select correct color system (See page 8.)
	An incorrect input has been selected on the TV or monitor.	Select the correct input on the TV or monitor.
No picture is displayed on the TV screen, the picture is blurred, or the picture is divided into two parts.	The PROGRESSIVE lamp are flashing though the unit is connected to a TV which does not support progressive video input, such as a conventional TV.	Press PROGRESSIVE until “INTERLACE” appears on the display. (See page 17.)
	The color system is not set correctly.	Change the color system. (See page 8.)
DVD does not play back.	Parental lock is in use.	Unlock the parental lock. (See page 65.)
The left and right edges of the picture are missing on the screen.	“4:3 PS” is selected when viewing on a conventional TV (aspect ratio 4:3).	Select “4:3 LB.” (See pages 11 and 61.)
No subtitle appears on the display though you have selected the initial subtitle language.		Some DVDs are programed to always display no subtitle initially. If this happens, press SUBTITLE after starting play. (See pages 40 and 61.)
Audio language is different from the one you have selected as the initial audio language.		Some DVDs are programed to always use the original language initially. If this happens, press AUDIO after starting play. (See page 41.)
Impossible to record.	Small tabs on the top of the cassette are removed.	Cover the holes with adhesive tape.
Stereo effect is lost.	Karaoke is activated.	Cancel the Karaoke mode. (See page 50.)
The disc playback sounds strange.	The key control has been adjusted.	Cancel the Key control. (See page 50.)
Operations are disabled.	The built-in microprocessor may malfunction due to external electrical interference.	Unplug the AC power cord and then plug it back in.
Unable to operate the unit from the remote control.	The path between the remote control and the remote sensor on the unit is blocked.	Remove the obstruction.
	The batteries are exhausted.	Replace the batteries.

Specifications

Amplifier

Output Power

FRONT SUBWOOFERS:

80 W per channel, min. RMS, driven into 6 Ω at 63 Hz with no more than 10% total harmonic distortion.

FRONT MAIN SPEAKERS:

45 W per channel, min. RMS, driven into 6 Ω at 1 kHz with no more than 10% total harmonic distortion.

CENTER SPEAKER:

45 W per channel, min. RMS, driven into 8 Ω at 1 kHz with no more than 10% total harmonic distortion.

SURROUND SPEAKERS:

25 W per channel, min. RMS, driven into 16 Ω at 1 kHz with no more than 10% total harmonic distortion.

Audio input sensitivity/Impedance

(Measured at 1 kHz, with tape recording signal 300 mV)

AUX: 300 mV/47 k Ω

Audio output level

MIC 1/2: 3.0 mV/50 k Ω

Digital output: OPTICAL DIGITAL OUTPUT

Signal wave length: 660 nm

Output level: -15 dBm to -12 dBm

Video output

VIDEO (composite): 1 V(p-p)/75 Ω

S-VIDEO:

Y (luminance) 1 V(p-p)/75 Ω

C (chrominance, burst) 0.286 V(p-p)/75 Ω

COMPONENT: (Y) 1 V(p-p)/75 Ω

(Pb, Pr) 0.7 V(p-p)/75 Ω

Speakers/Impedance

FRONT SUBWOOFERS: 6 Ω – 16 Ω

FRONT MAIN SPEAKERS: 6 Ω – 16 Ω

CENTER SPEAKER: 8 Ω – 16 Ω

SURROUND SPEAKERS: 16 Ω – 32 Ω

Tuner

FM tuning range: 87.50 MHz – 108.00 MHz

AM tuning range:

For Saudi Arabia 531 kHz – 1 602 kHz
(At 9 kHz intervals)

530 kHz – 1 600 kHz

(At 10 kHz intervals)

For other countries 531 kHz – 1 710 kHz

(At 9 kHz intervals)

530 kHz – 1 710 kHz

(At 10 kHz intervals)

DVD player

Disc capacity:

5 discs

Readable disc:

DVD VIDEO, DVD-R, DVD-RW, S-Video CD, Video CD, CD, CD-R, CD-RW

Frequency response

DVD, fs=48 kHz:

16 Hz to 22 000 Hz

DVD, fs=96 kHz:

16 Hz to 44 000 Hz

SVCD, VCD, CD:

16 Hz to 20 000 Hz

Dynamic range:

85 dB

Signal-to-noise ratio:

90 dB

Wow and flutter:

Immeasurable

Cassette deck

Frequency response

Normal (type I):

50 Hz – 14 000 Hz

Wow and flutter:

0.15% (WRMS)

General

Power requirement:

AC 110 V / AC 127 V / AC 220 V / AC 230 V – AC 240 V \sim (adjustable with the voltage selector), 50 Hz / 60 Hz

Power consumption:

220 W (at operation)

29 W (on standby)

Dimensions (approx.):

205 mm x 370 mm x 380.5 mm (W/H/D)

Mass (approx.):

11.5 kg

Supplied accessories

See page 6.

Mains (AC) Line Instruction (not applicable for Europe, U.S.A., Canada, Australia, and U.K.)

主 (AC) 电源线路说明 (不适用于香港、欧洲、美国、加拿大、澳大利亚及英国型号)

تعليمات خط التيار الكهربائي المتردد الرئيسي (المتردد) (لا تنطبق على هونج كونج واوروبا والولايات المتحدة الامريكية وكندا واستراليا والمملكة المتحدة)

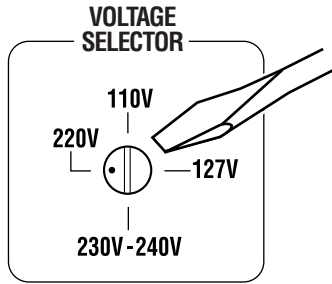

CAUTION for mains (AC) line

BEFORE PLUGGING IN, do check that your mains (AC) line voltage corresponds with the position of the voltage selector switch provided on the outside of this equipment and, if different, reset the voltage selector switch, to prevent from a damage or risk of fire/electric shock.

有关主 (AC) 电源线路的重要事项

接插电源以前，请务必检查当地的主 (AC) 电源线路电压是否和位于本机外面的电压选择开关设定的位置一致。如果不一致，请重新设定电压选择开关使其符合当地电压，以免损坏机器或引起火灾/触电的危险。

هام من اجل خط التيار الكهربائي الرئيسي الرئيسي (المتردد) قبل ادخال قابس الطاقة الكهربائية، تأكد من تطابق منتخب فولطية التيار الكهربائي الرئيسي (المتردد) الموجود على خلفية الجهاز مع فولطية التيار الكهربائي في بلدك. في حالة عدم التطابق، اعد ضبط مفتاح منتخب الفولطية على فولطية التيار الكهربائي في بلدك. عدم عمل ذلك، يمكن ان يؤدي الى حصول ضرر او حريق او صدمة كهربائية.

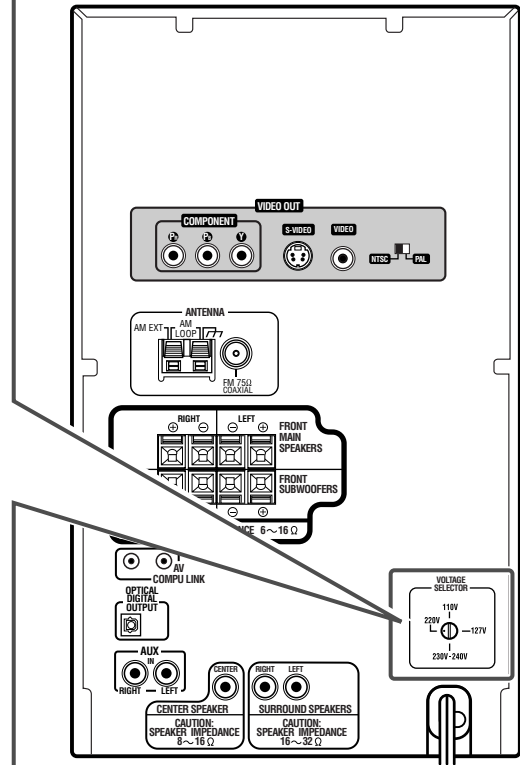

JVC

VICTOR COMPANY OF JAPAN, LIMITED